



**EEIG ERTMS Users Group**

123-133 Rue Froissart, 1040 Brussels, Belgium

Tel: +32 (0)2 673.99.33 - TVA BE0455.935.830

Website: [www.ertms.be](http://www.ertms.be) E-mail: [info@ertms.be](mailto:info@ertms.be)

**ERTMS USERS GROUP – ENGINEERING GUIDELINE**

**78. Level transition from L2 to LNTC**

Reference: 19E191  
Version: 3-  
Date: 2024-06-28

**Modification history**

Version	Date	Modification / Description	Editor
0.1	11/03/2019	Update for Baseline 3 trackside, based on EUG_71 v2.0	A. Meijer
0.2	18/04/2019	Update based on ESG74 and review AB, RO	A. Meijer
0.3	29/05/2019	Update based on ESG75	A. Meijer
0.4	19/07/2019	Update based on ESG76, review GR	A. Meijer
1.0	10/10/2019	Version 1.0 released	ESG
1a	18/06/2021	Opinion ERA-OPI-2020-2 incorporated	A. Meijer
2-	30/06/2021	Version 2- released	ESG
2a	2023-04-19	Reference number 19E153 replaced by 19E191 due to duplication General update of references Formatting and editorial changes	A. Bäärnhielm
2b	2024-03-27	Corrections to document style and layout, and editorial corrections.	A. Bäärnhielm
3-	2024-06-28	Official version	C. Zieleman

## Table of Contents

1.	Introduction .....	5
1.1	Foreword .....	5
1.2	Scope and Field of Application .....	5
1.3	Document structure .....	6
2.	References and Abbreviations .....	7
2.1	Definitions.....	7
2.2	Abbreviations.....	7
2.3	References .....	8
3.	Transition from level 2 to level NTC .....	9
3.1	Introduction.....	9
3.2	Functional Steps.....	9
3.3	General Track Layout .....	9
3.4	General Sequence Diagram .....	10
4.	Issues to be addressed.....	12
4.1	Introduction.....	12
4.2	Issues.....	12
4.2.1	Loss of route protection in the route from the ETCS border .....	12
4.2.2	Authorisation across the ETCS border .....	12
4.2.3	Allow level transition at line speed .....	12
4.2.4	Avoid contradiction between line side and cab signalling .....	13
4.2.5	Announcement of level transition .....	13
4.2.6	Driver acknowledgement of level transition .....	13
4.2.7	Avoid Level Transition Announcement for diverging trains .....	14
4.2.8	Manual cancellation of the route from the ETCS border.....	14
4.2.9	Start of mission in rear of the ETCS border.....	14
4.2.10	Allow transition with On-sight routes to and/or from the ETCS border .....	15
4.2.11	Minimise the use of switchable balises.....	15
4.2.12	Management of TSRs in the area in advance of the ETCS border .....	16
4.2.13	Management of speed restrictions beginning in rear of the ETCS border .....	16
4.2.14	Management of National Values .....	17
4.2.15	Manual level selection in rear of the ETCS border .....	17
4.2.16	Protect EOA in rear of the ETCS border .....	18

4.2.17	Approaching the border in SR mode .....	18
4.2.18	Restrictive mission at the level transition.....	19
4.2.19	Level transition with STM not present and no other levels are admitted .....	20
4.2.20	Approaching the border in SH mode .....	20
4.2.21	Geographical position after ETCS border.....	21
4.2.22	Location ETCS border.....	21
5.	Recommended solutions.....	22
5.1	Level Transition Announcement and MA .....	22
5.1.1	Basic considerations .....	22
5.1.2	Track layout .....	22
5.1.3	Sequence diagram.....	24
5.1.4	Authorisation across the ETCS border .....	25
5.1.5	Alternative solution .....	27
5.1.6	Degraded situations.....	27
5.2	Level NTC Transition .....	28
5.2.1	Basic considerations .....	28
5.2.2	Track layout .....	28
5.2.3	Sequence diagram.....	28
5.2.4	Degraded situations.....	29
5.3	General Recommendations for Transition to level NTC .....	30
5.3.1	Balises.....	30
5.3.2	National Values.....	30

## **1. Introduction**

### **1.1 Foreword**

- 1.1.1.1 The procedure for level transitions is defined technically in chapter 5 of the SRS (see SUBSET-026 [2] and operationally the harmonised ERTMS rules apply (see OPE TSI [1]) in addition to national rules. The procedures possible for transitions from level 2 to level NTC are very flexible and currently there are many different ERTMS implementations dealing with this issue from which some are based on ERTMS/ETCS Baseline 3.
- 1.1.1.2 The aim of this document is to define a set of recommended trackside solutions for the engineering of transitions from an area only equipped for level 2 to level NTC for the benefit of future ERTMS projects. The objective is to support an efficient and safe implementation of ERTMS, both from a technical and operational point, simplifying and harmonising future system implementations taking advantage of the experience obtained from projects already in operation.
- 1.1.1.3 This guideline is part of a bundle of guidelines with the Overall ETCS guideline [9] being the main guideline which will redirect the reader to the relevant guidelines. Be aware that the Overall ETCS guideline may also include recommendations which are related to the topics addressed in this guideline.

### **1.2 Scope and Field of Application**

- 1.2.1.1 This document is based on ERTMS/ETCS Baseline 3 Release 2 including ERA/OPI/2020-2 [8] and is applicable for transitions from an area only equipped with ETCS level 2 to an area only equipped with level NTC.
- 1.2.1.2 Some ERTMS functions, controls or information are considered out of scope of this document because they are not directly related to the transition procedure:
- Track conditions information is considered as general information to be sent to the train independent of the transition and thus out of scope for this document.
  - The specific national trackside equipment requirements are project specific and not part of this guideline.
  - Optical signals, e.g. for the level NTC area, are project specific and out of the scope of this guideline
- 1.2.1.3 It is strongly recommended that any entity using ERTMS/ETCS follows the recommendations defined in this document.
- 1.2.1.4 This guideline is based on the requirements of SUBSET-035 [3] as far as relevant for trackside engineering.
- 1.2.1.5 Bespoke interface between EVC and the national system or the case of no interface between the national system and the EVC are out of the scope of this guideline however provisions contained in this guideline can be also used in case of customised interface.

1.2.1.6 This guideline is applicable for a trackside with System Version 2.1.

1.2.1.7 However, this guideline takes into consideration the following on-board systems:

- On-board systems supporting System Version 1.Y and 2.Y, with active System Version 2.Y when approaching the level transition (i.e. B3MR1, B3R2 and B3R2+ERA/OPI/2020-2 [8] on-boards).

### **1.3 Document structure**

1.3.1.1 Chapter 1 introduces the document and defines the scope.

1.3.1.2 Chapter 2 provides references, terms and abbreviations used in this document.

1.3.1.3 Chapter 3 provides the general functional steps for transition to level NTC.

1.3.1.4 Chapter 4 provides the criteria assessed for the recommendations.

1.3.1.5 Chapter 5 provides the recommendations for each functional step.

## 2. References and Abbreviations

### 2.1 Definitions

2.1.1.1 The following table includes terms and definitions which are used in the current document:

Terminology	Definition
<u>ETCS area</u>	The area in between ETCS borders with infrastructure for trains running in ETCS levels 1, 2 or 3
<u>ETCS border</u>	The location where the ETCS level is changed
<u>Level NTC approach area</u>	The area in rear of the ETCS border to facilitate the transition to level NTC
<u>Level NTC area</u>	The area in advance of the ETCS border
<u>On-sight route</u>	A locked route which is not unambiguously detected free

### 2.2 Abbreviations

2.2.1.1 The following table includes acronyms and abbreviations which are used in the current document:

Abbreviation	Description
ATP	Automatic Train Protection (national systems)
BG	Balise Group
CS	STM state Cold Standby
DA	STM state Data Available
DMI	Driver Machine Interface
EOA	End of Authority
FA	STM state Failure
HS	STM state Hot Standby
LOA	Limit of authority
LTA	Balise group for Level Transition Announcement
LTC	Balise group for Level Transition Cancellation
LTO	Balise group for Level Transition Order
M	Message, e.g. M39 is ETCS message 39
MA	Movement Authority

OS	On-Sight (ETCS mode)
P	Packet, e.g. P41 is ETCS packet 41
RBC	Radio Block Centre
SoM	Start-of-Mission; procedure for start-up of an ERTMS/ETCS train
SR	Staff Responsible (ETCS mode)
SSP	Static Speed Profile
STM	Specific Transmission Module (for national ATP systems)
TSR	Temporary Speed Restriction

## 2.3 References

2.3.1.1 The following documents and versions apply:

Ref. N°	Document Reference	Title	Version
[1]	TSI OPE	Annex A, TSI OPE, 2012/464/EC, ERTMS rules and Principles	v4
[2]	SUBSET-026	ERTMS/ETCS Class 1 System Requirements Specification	3.6.0
[3]	SUBSET-035	Specific Transition Module FFFIS	3.2.0
[4]	SUBSET-036	FFFIS for Eurobalise	3.1.0
[5]	SUBSET-040	Dimensioning and Engineering rules	3.4.0
[6]	SUBSET-041	Performance Requirements for Interoperability	3.2.0
[7]	SUBSET-113	ETCS Hazard Log	1.4.0
[8]	ERA/OPI/2020-2	Opinion of the European Union Agency for Railways to the European Commission regarding error corrections of current ERTMS baselines	2020-05-05
[9]	22E087	Overall ETCS	1-



### 3. Transition from level 2 to level NTC

#### 3.1 Introduction

3.1.1.1 This chapter intends to give a general overview of how to perform a transition from level 2 to level NTC and can be used as a reference for the issues discussed in chapter 4. The track layout and sequence diagram presented here are further detailed in chapter 5, as applicable for each functional step.

#### 3.2 Functional Steps

3.2.1.1 In order to facilitate the recommendations detailed in chapter 5, the transition to level NTC is divided into the following functional steps:

- 1) Level transition announcement and MA
- 2) Level NTC transition

#### 3.3 General Track Layout

3.3.1.1 Figure 1 shows the general and relevant track design and balise groups needed to perform the different functional steps of the transition from level 2 to level NTC listed in section 3.2.1.1.

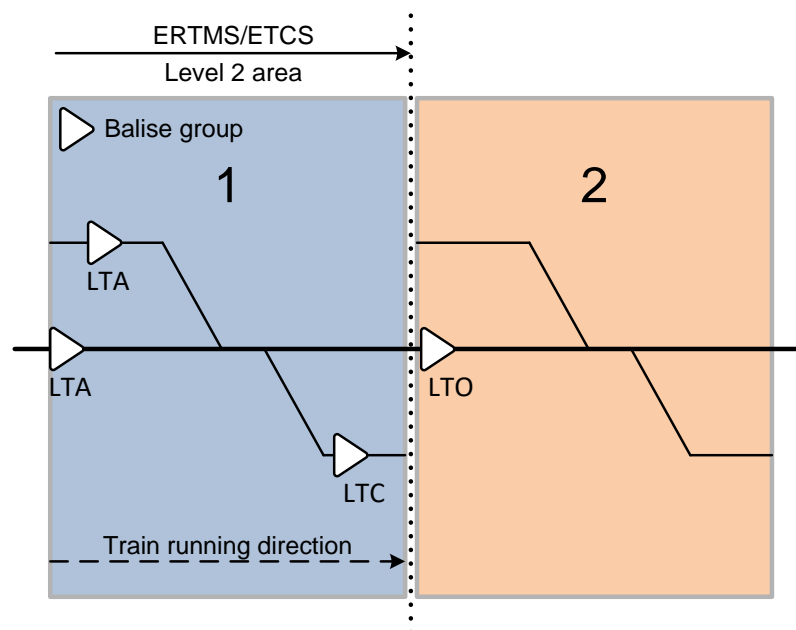

Figure 1: Generic track layout for transition from level 2 to level NTC

3.3.1.2 There are intentionally no signals shown in this figure as they are not relevant for the transition procedure as such from a technical point of view.

3.3.1.3 Table 1 below represents the balise groups and information (in ETCS packets) for each functional step for a transition from level 2 to level NTC. The need for these balise groups and other alternative balise groups and packets will be described in chapter 5.

BG	BG DESCRIPTION	BG INFORMATION (ETCS PACKETS)
LTA	Level Transition Announcement	Packet 41: Level Transition Order announcing the transition to level NTC at the ETCS border
LTC	Level Transition Cancellation	Packet 41: Level Transition Order with immediate transition to level 2; this cancels the announced transition to level NTC
LTO	Level Transition Order	Packet 41: Level Transition Order with immediate transition to level NTC

Table 1: Balise groups for transition from level 2 to level NTC

- 3.3.1.4 The information in the balise groups in the figures is only valid in the indicated train running direction, unless defined otherwise.
- 3.3.1.5 The balise group LTA announces the transition to level NTC; this can also be done by the RBC and the conditions for doing that are described in chapter 5.
- 3.3.1.6 The LTC balise group cancels the transition in case the train is routed away from the ETCS border after the Level Transition Announcement has been received; this can also be done by the RBC and the conditions for doing that are described in chapter 5.
- 3.3.1.7 The LTO balise group is located at the ETCS border and orders the immediate transition to level NTC.

### 3.4 General Sequence Diagram

- 3.4.1.1 The sequence diagram in Figure 2 shows the relevant information that is exchanged between the main actors when performing the transition to level NTC according to the functional steps listed in 3.2.1.1 above.

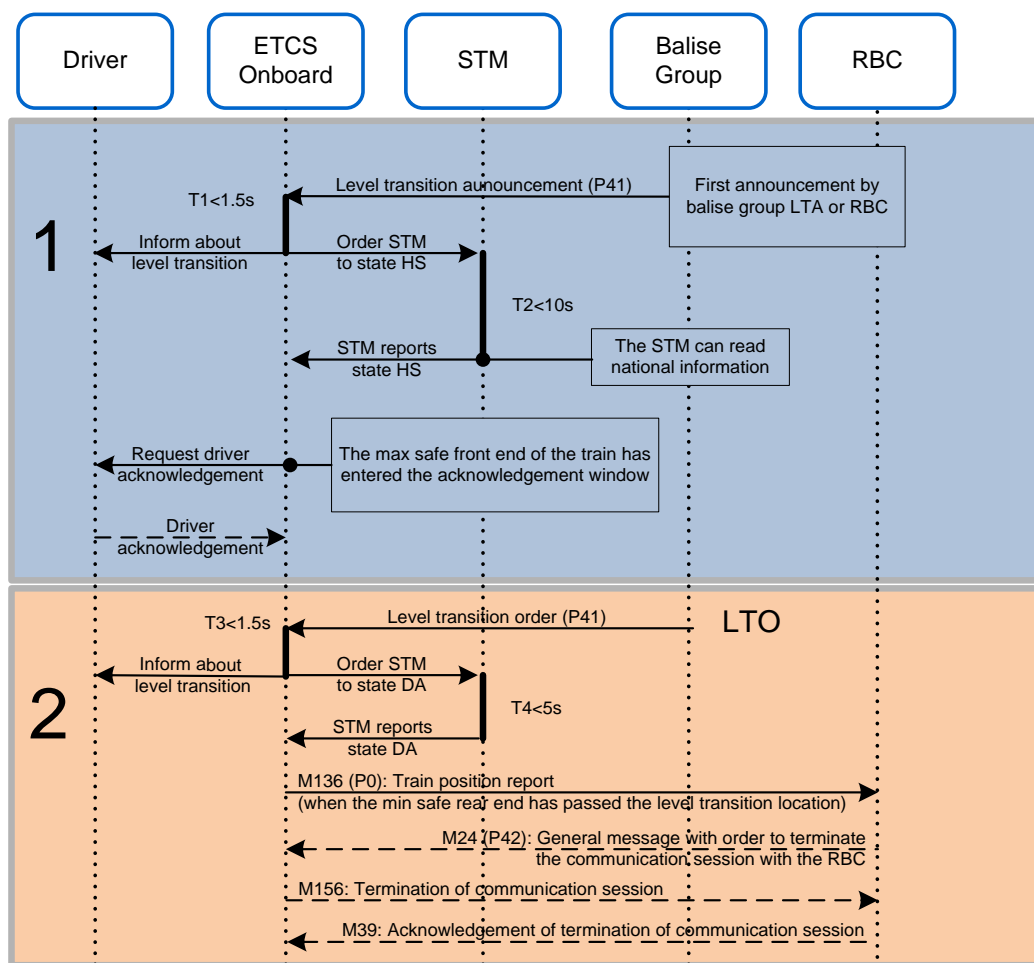

Figure 2: General sequence diagram for transition from Level 2 to level NTC

- 3.4.1.2 The Level Transition Announcement is given by RBC and could be given also by balise group LTA. The actual sequence depends on conditions which are detailed in 5.1.
- 3.4.1.3 The above diagram does not represent all information exchanged by the relevant actors but defines in general the different functional steps that are considered in this document.
- 3.4.1.4 The arrow for driver acknowledgement is 'dashed' as it is not absolutely needed because the level transition will take place also without it. The driver can acknowledge before the level transition is executed (from the location specified in the transition announcement) or within 5 seconds after the transition (see SUBSET-026 [2] 5.10.4.2); i.e. in step 1 or 2.
- 3.4.1.5 Step 1 ends and step 2 starts when the LTO balise group is read.
- 3.4.1.6 The arrows for terminating the communication session, M24, M156 and M39 are 'dashed' because they are not important for the transition as such.

## **4. Issues to be addressed**

### **4.1 Introduction**

4.1.1.1 This chapter lists the issues that need to be considered for the transition from level 2 to level NTC and some of them are further detailed in the recommended solutions given in chapter 5. The issues that are not part of the recommended solutions are mentioned in this chapter because projects may still need to consider them.

### **4.2 Issues**

#### **4.2.1 Loss of route protection in the route from the ETCS border**

4.2.1.1 There must be a safe reaction in case of failure of one or more supervised conditions aiming to protect the route in advance of the ETCS border (e.g. unexpected track occupation).

4.2.1.2 The system that detects the loss of route protection is responsible to take action to resolve the hazardous situation, e.g. by informing the adjacent RBC and the national system to try to stop an affected train. The RBC can then withdraw the authorisation it has given for entering the level NTC area by sending a shortened MA or an Emergency Stop message.

4.2.1.3 There is no direct impact on the transition procedure, only on the possibility to approach and pass the ETCS border. Thus, this issue is not further considered in chapter 5.

#### **4.2.2 Authorisation across the ETCS border**

4.2.2.1 The authorisation into the level NTC area can be implemented with a Level 2 MA with EOA in the level NTC area or with LOA at the border, both considering speed restrictions (e.g. TSRs) in the level NTC area relevant for calculating safe supervision limits and the braking curves used by ETCS and the national system.

4.2.2.2 The allowed ETCS speed at the level transition location must not exceed the speed allowed in the level NTC area. This speed and location can be provided by the trackside system and/or STM if supported (see SUBSET-035 [3]). The allowed speed in the level NTC area may also depend on national train categories.

4.2.2.3 The authorisation across the ETCS border is considered in section 5.1.4.

#### **4.2.3 Allow level transition at line speed**

4.2.3.1 Trains approaching the level NTC area should not face speed restrictions caused by the transition procedure to level NTC, but depending on the STM in use it may be necessary to reduce the speed to be able to read national system information in rear of the ETCS border and this is considered in section 5.1.4.

4.2.3.2 This may also be an engineering issue for the first block in advance of the ETCS border if a Level 2 MA is used with an EOA in the level NTC area because the speed supervision in the ERTMS/ETCS on-board may be more restrictive than

that of the national system. Thus, it might not be possible to approach the ETCS border at the line speed allowed in level NTC area unless the first block section in the level NTC area is long enough.

4.2.3.3 Alternatively, RBC can send a permitted braking distance at the ETCS border with the braking distance to the next signal supervised in level NTC. So the speed at the ETCS border is adapted on the available braking distance in level NTC area.

4.2.3.4 This issue is not further considered in chapter 5 as the decision for which situations the level transition should be possible at line speed is project specific.

#### **4.2.4 Avoid contradiction between line side and cab signalling**

4.2.4.1 Unclear or overlapping responsibilities of two signalling systems can give different and contradicting signalling information to the driver. This could be caused by different delays, different signalling principles (e.g. cab signalling, speed signalling / distance to go, different track information, different odometers, etc.).

4.2.4.2 This issue is avoided by synchronisations of the involved signalling systems or a clear split of responsibility at the ETCS border.

4.2.4.3 This issue is project specific and it has no impact on the transition procedure therefore it is not further considered in chapter 5.

#### **4.2.5 Announcement of level transition**

4.2.5.1 The announcement to level NTC must provide both the driver and the STM with enough time to prepare for the level transition. This is considered in section 5.1.

4.2.5.2 According to the ERTMS rules in the OPE TSI [1], the driver shall apply national rules when the announcement to level NTC is shown.

#### **4.2.6 Driver acknowledgement of level transition**

4.2.6.1 The driver will be requested to acknowledge the transition to level NTC, except if the on-board is in non-leading (NL) mode. This request to acknowledge can appear either at a certain distance in rear of the ETCS border (if specified in the Level Transition Announcement) or when switching the level.

4.2.6.2 According to the ERTMS rules in the OPE TSI [1], the driver shall apply national rules when the announcement to level NTC is shown. Thus, the acknowledgement distance should give the driver time to prepare for the transition according to national rules (e.g. time to observe the optical signal to prepare to switch from cab signalling to lineside signals).

4.2.6.3 The acknowledgement distance in rear of the border can be determined from the time considered acceptable for the driver before making the transition. This time shall consider the line speed and that the announcement must be transmitted in rear of the required acknowledgement distance/time, including the required processing time of the Level Transition Announcement. If the driver is not required to acknowledge in rear of the border, the distance is set to zero.

4.2.6.4 When it is possible that another acknowledgement is required (e.g. change of mode, text message) at the ETCS border the abovementioned time shall also consider 6 seconds acknowledgement time before start of mode profile or start of displaying text message (see SUBSET-113 [7] ETCS-H0088).

4.2.6.5 When requested to acknowledge, the driver should do so within 5 seconds after making the transition, as otherwise the train will be braked; see SUBSET-026 [2] 5.10.4.2.

4.2.6.6 This issue is considered in section 5.1 together with the announcement, i.e. in functional step 1, even if the driver may acknowledge in step 2.

#### **4.2.7 Avoid Level Transition Announcement for diverging trains**

4.2.7.1 Vehicles moving in the level NTC approach area should not receive a Level Transition Announcement (which has to be displayed to the driver) or be forced to make a level transition unless they are routed into the level NTC area.

4.2.7.2 This problem can be avoided if the level 2 system only announces the level transition if the train is routed into the level NTC area, but it may be necessary to announce the transition also for trains that will finally not enter the level NTC area if the NTC is required to read information from the national system infrastructure already in rear of the location of the last diverging route.

4.2.7.3 If the announcement cannot be avoided for diverging trains then it must be cancelled before the level transition is performed by the ERTMS/ETCS on-board and preferably before the driver is requested to acknowledge the level transition.

4.2.7.4 This issue is considered in functional step 1 in section 5.1.

#### **4.2.8 Manual cancellation of the route from the ETCS border**

4.2.8.1 In case the route into the level NTC area is cancelled manually for operational purposes (e.g. for preferred vehicle movements, change of departure sequence, etc.), the authorisation to cross the ETCS border must be revoked. This can be achieved by an updated (shortened) Movement Authority or by Co-operative shortening of MA, but only if it can be sent to the affected train.

4.2.8.2 The risk of a lost safe connection between the train and the RBC is supervised by T\_NVCONTACT, but the risk that route release is handled differently at each side of the border can be mitigated by using section timers. Values for section timers must be dimensioned considering the interlocking route release timers in the applicable area.

4.2.8.3 This issue is considered in section 5.1.4.

#### **4.2.9 Start of mission in rear of the ETCS border**

4.2.9.1 ERTMS/ETCS trains always have the possibility to perform start-of-mission in the area in rear of the ETCS border, but the selection of ETCS level(s) is limited by a table of priority of trackside supported levels if available on-board the train. This

table is assumed to contain only the applicable level, therefore the train is assumed to start in level 2 in rear of the ETCS border.

4.2.9.2 In project specific situations it could be an operational benefit to have level NTC in the table of priority of trackside supported levels in rear of the border. This would create a mixed level area which is out of scope for this guideline.

4.2.9.3 In case the table of priority of trackside supported levels is not available, i.e. after NP mode if cold movement detected or without cold movement information, the default list of levels configured on-board will be used. This list includes all the levels fitting the trackside infrastructures where the train has been granted access, see SUBSET-040 [5] 4.4.2. This could lead to wrong level selection during start of mission procedure in rear of the ETCS border. Additional mitigations for the risk signal passed at danger could be required in rear of danger points, e.g. a (switchable) balise group with level transition order to level 2 if signal is at danger. This will stop trains in wrong level without movement authority. Depending on the national system also adding protection by the national system equipment could be considered.

4.2.9.4 After start of mission, the transition announcement to level NTC can be given with the Level 2 MA to cross the border. If this level 2 MA cannot be given, the transition to level NTC can be performed in SR mode.

4.2.9.5 This issue is considered in section 5.1.

#### **4.2.10 Allow transition with On-sight routes to and/or from the ETCS border**

4.2.10.1 The possibility for the RBC to inform a train approaching the ETCS border that there is an On-sight route from the border, depends on the information available from the systems in that area. In case the RBC can inform the train about such an On-sight route, this could result in simultaneous requests for driver acknowledgement, one for the level transition and one for the entry in OS mode.

4.2.10.2 To avoid confusion on requested acknowledgements with an On-sight route starting at the ETCS border, separation between the acknowledgement windows for the level transition and the OS mode should be considered.

4.2.10.3 Considerations on On-sight routes in the level NTC area are project specific because of the possibility to get such information and therefore not further detailed in chapter 5.

4.2.10.4 There is no issue with an On-sight route to the ETCS border as this is part of the MA to approach the border.

#### **4.2.11 Minimise the use of switchable balises**

4.2.11.1 Switchable balises should be avoided due to the extra costs and lower availability compared with fixed balises, but there are cases where they can be useful.

4.2.11.2 The transition to level NTC can be achieved using only fixed balises and the balises in the recommendations in chapter 5 are fixed unless explicitly stated to be switchable for a well-defined purpose.

#### **4.2.12 Management of TSRs in the area in advance of the ETCS border**

- 4.2.12.1 The systems on both sides of the ETCS border must take into account speed restrictions having an impact on the train speed profile. It is possible to transmit TSRs from the RBC and/or balise groups.
- 4.2.12.1.1 Note: Braking curves may differ between ERTMS/ETCS and the national system. This could lead to the risk of missing the indication to a TSR for trains with good brake performance.
- 4.2.12.2 A temporary speed restriction in advance of the ETCS border, i.e. within the level NTC area, known by the RBC and sent to the train, allows this speed reduction to be taken into consideration by the train before entering the level NTC area. Even if the national system is installed in rear of the ETCS border, TSRs located in advance of the ETCS border (in the level NTC area) may only be read by the STM in state Hot Standby and supervised when in state Data Available. The fact that STM needs to be in Hot Standby in rear of the location where the national infrastructure is installed must be taken into account for the level transition announcement.
- 4.2.12.3 Extension of a TSR location within level NTC area to the ETCS border should be considered if the announcement distance is too short.
- 4.2.12.4 This issue has no further impact on the transition procedure and is not considered in chapter 5.

#### **4.2.13 Management of speed restrictions beginning in rear of the ETCS border**

- 4.2.13.1 In a ETCS level 2 area the driver observes only cab signalling and must not observe most line side signals. In a pure level 2 area no line side signals for speed restrictions are installed. Due to lack of harmonized rule in the OPE TSI [1], the driver must observe line side signals according to national operational rules for instance if the level transition to level NTC is announced or if the driver has acknowledged the level transition.
- 4.2.13.2 If a speed restriction is beginning in rear of the ETCS border in level 2 and ending in advance of the ETCS border in the level NTC for the minimum safe front end, the driver might have not observed the line side signal for the speed restriction in level 2 (see chapter 4.2.13.1 and 4.2.13.5) and is therefore not aware of the still relevant speed restriction in the level NTC area. Even if the train exits level 2 with the correct speed restriction, the driver might accelerate the train before the minimum safe rear end has passed the end of the speed restriction. The following possible solutions could solve this issue.
- 4.2.13.3 The STM should supervise speed restrictions in level NTC until the minimum safe rear end has passed the end of the speed restriction. National trackside STM infrastructure for the relevant speed restrictions should be placed in rear of the ETCS border in the level 2 area or at the ETCS border. This is valid if the STM train device fulfils the STM state HS requirements in SUBSET-035 [3].



- 4.2.13.4 Additional line side signals for the speed restriction may be repeated at the ETCS border, so that the driver can observe the speed restriction in level NTC area. This is only an operational solution and might not be sufficient for national safety requirements.
- 4.2.13.5 These solutions might not be possible for route depending speed restrictions in rear of the ETCS border and diverging routes to level NTC because of points. In addition, in this situation the level announcement might be sent quite late if the route is set to level NTC area and the train has already passed the relevant speed restriction line side signal.
- 4.2.13.6 To avoid this situation a possible solution is to plan a distance of at least the maximum train length between the location where a speed limit (e.g. speed at point or TSR) changes and the level transition to level NTC as depicted in Figure 3.

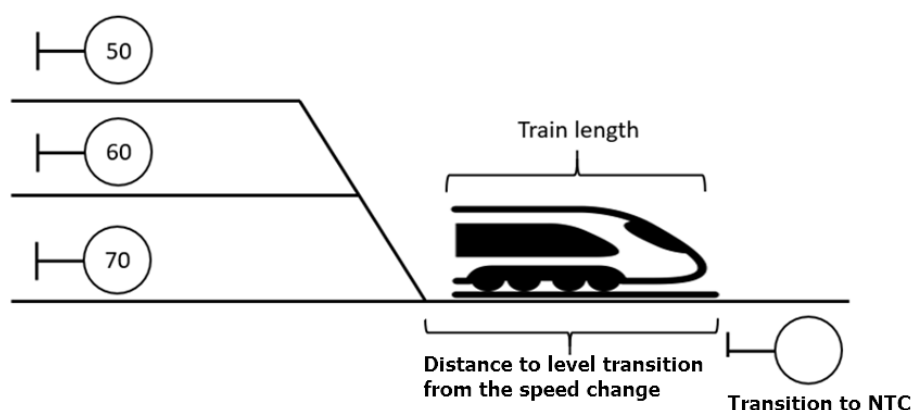

Figure 3: Train length shall be smaller than the distance to the level transition point

- 4.2.13.7 As possible alternative solution, the RBC could send a text message with the still relevant speed restriction (either relevant for train front end or for train rear end, depending on the end of the speed restriction), if the level transition to level NTC is announced.
- 4.2.13.8 This issue is project specific and is not considered in chapter 5.

#### 4.2.14 Management of National Values

- 4.2.14.1 The ERTMS/ETCS train that exits the ETCS area should have the correct National Values stored on-board for the level NTC area. This can be achieved, also for ERTMS/ETCS on-board units that cannot receive them from the RBC (e.g. in SL mode), by transmitting them from a balise group (see section 5.3).

#### 4.2.15 Manual level selection in rear of the ETCS border

- 4.2.15.1 The train driver may manually select level when the train is at standstill. In case level NTC is available for manual selection (e.g. by using the default list of levels configured on-board when no level transition order to level 2 is received after deleting the table of priority), the driver could change to level NTC already in rear of the border and (depending on the national system) move in the level 2 area.

4.2.15.2 This is potentially unsafe and can be avoided by using a packet 46, Conditional Level Transition Order, not including level NTC in a balise group in rear of the ETCS border.

4.2.15.3 As the train is expected to be operated in the level applicable for the area where it is located, this issue is not further considered in chapter 5.

#### 4.2.16 Protect EOA in rear of the ETCS border

4.2.16.1 When the EOA is close to the ETCS border there is a risk that the transition to level NTC is performed before the min safe front end of the train reaches the EOA due to odometer inaccuracies, see Figure 4. This could pose a risk, since after switching to level NTC the on-board does not supervise its previous EOA anymore. Depending on the national system, this risk should be mitigated.

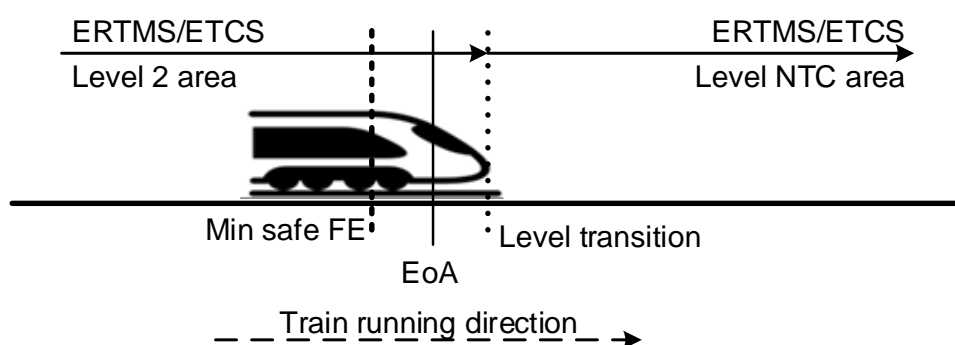

Figure 4: EOA in rear of ETCS border

4.2.16.2 This is solved by proper engineering of the ETCS border in relation to the last EOA in rear of the border and this issue is considered in section 5.2.

#### 4.2.17 Approaching the border in SR mode

4.2.17.1 Trains may be moving in SR mode in rear of the ETCS border for various reasons, e.g. after start-of-mission or after selecting Override EOA.

4.2.17.2 Preventing trains to pass the ETCS border in SR mode is out-of-scope of this guideline as this is considered normal procedure for protecting a specific location, e.g. by using a balise group with ETCS packet 137: Stop if in SR. Thus, preventing trains to pass the border in SR is not considered in chapter 5.

4.2.17.3 Trains that are supposed to approach the ETCS border in SR mode should preferably receive a Level Transition Announcement in rear of the border to prepare both the driver and the STM for the transition to the national system, as for normal train movements.

4.2.17.4 This issue is considered in section 5.1.

4.2.17.5 If driver selected Override EOA in rear of the ETCS border the DMI will stop displaying the indication status “override active” to the driver on executing the transition to level NTC although the (national) override function could still be active.

4.2.17.5.1 Note: The indication status “override active” is never displayed in level NTC. This section is not applicable for B3MR1 on-boards.

#### 4.2.18 Restrictive mission at the level transition

4.2.18.1 A driver must never face a restrictive mission (stop or speed decrease) located just after the level transition to level NTC without being warned at the appropriate distance in rear of this restriction.

4.2.18.2 In particular, train with good braking performance (dotted in Figure 5) may not display the braking indication to the driver before the transition point. As an example, when the speed drops right after the border transition because there is a closed signal near the border transition. Due to very short braking distances, the train could approach the closed signal faster than is appropriate to level NTC operation. This is considered in section 5.1.4.

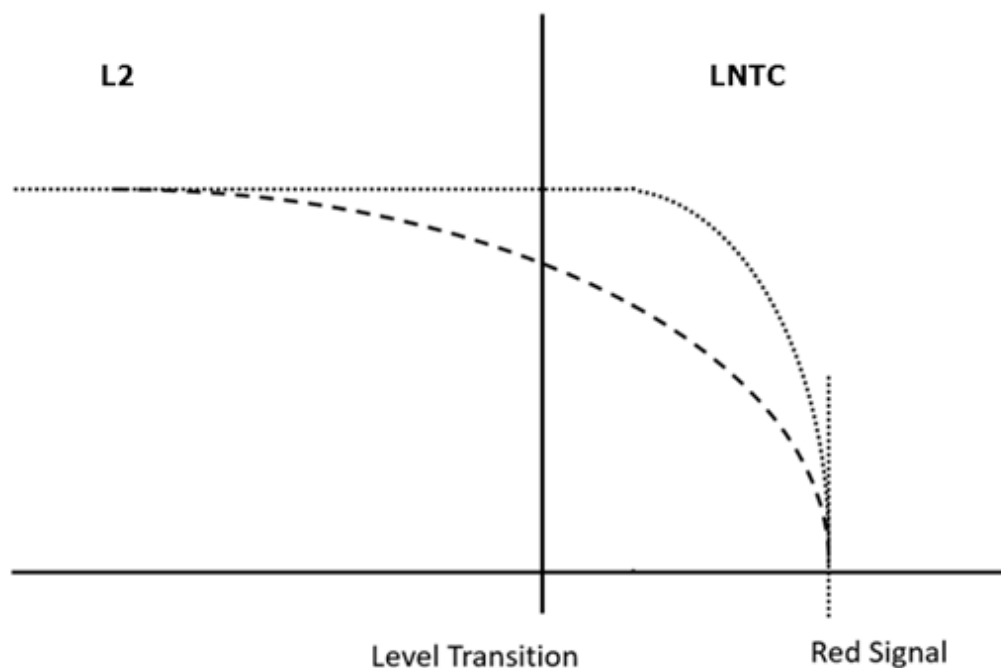

Figure 5: Train with good braking performance (dotted) and poorer braking performance (dashed)

4.2.18.3 If the DMI displays warning information received from the STM in state HS (see SUBSET-035 [3] 13.2.1.5 and 13.2.1.5.1), when it switches to state DA, LTA and LTO BG could be located so that there is a STM wayside device in between them to warn for the restrictive mission after the LTO BG.

4.2.18.4 If the LTA BG is located in advance of the national system device, a specific operational rule can be necessary to ask the driver to take into consideration the most restrictive mission among the one displayed on the DMI and the one displayed by the lateral signalling (if any) when a level transition is announced to the driver.

4.2.18.5 If the STM warning information is not displayed to the driver when the STM device switches to state DA, the protection of the speed reduction or the stop shall be ensured by an ETCS speed reduction at the level transition border.

4.2.18.6 This topic is project specific and is not considered in chapter 5.

#### **4.2.19 Level transition with STM not present and no other levels are admitted**

4.2.19.1 According to SUBSET-026 [2] chapter 5, when trackside orders a transition to level NTC with a national system (packet 41 or 46) which is not available on-board, the OBU shall nevertheless make the transition.

4.2.19.2 The issue is the following: if no other levels are in the list of the ordered level(s) in packet 41 or 46 (e.g. level 0 is not allowed), the transition takes place but train protection is not more provided unless national system is present and active (but unknown to EVC).

4.2.19.3 The STM not being present, no STM control function is active (i.e. no STM max Speed).

4.2.19.4 In this case the OPE TSI [1] refers to non-harmonised rules.

4.2.19.5 According to SUBSET-026 [2] 5.10.2.6 and 5.10.2.7.1, the OBU has to indicate to the driver the new level.

4.2.19.6 The trackside engineering (or route compatibility rules) should consider this issue to prevent trains from running unprotected within level NTC area unless national operational rules allow it.

4.2.19.7 A possible solution is that level 0 is added at the end of the table of priority of trackside supported levels and by sending National Values with a restricted unfitted mode speed limit.

4.2.19.8 Another possible solution is that RBC should consider the available STM sent in the train data. If the required STM is not included in the received train data, the RBC should stop the train without the required STM at the ETCS border with an EOA.

4.2.19.9 This topic is project specific and is not considered in chapter 5.

#### **4.2.20 Approaching the border in SH mode**

4.2.20.1 There is no restriction to approach and pass the border in level 2 SH mode, however in level 2 SH mode the on-board does not manage transition orders. An announcement of a transition order is ignored, and an immediate transitions order is stored and only used when leaving SH mode (including PS mode).

4.2.20.2 An issue is that in the level NTC area there could be no mitigations to prevent trains running in level 2 SH mode to pass signals at danger. Even if there are mitigations present, e.g. stop-if-in-SH balises placed in the level NTC area, this will lead to a trip and at the same time a transition to level NTC. Leaving trip, the train will automatically continue in level NTC SH mode and the national system, if an STM is used, is still not activated, i.e. the STM state changes to Cold Standby when entering level NTC SH mode (see SUBSET-035 [3] 10.3.2.2, 10.3.2.4 condition I4a).

4.2.20.3 If passing the border in SH mode is required a possible solution is a procedure that after passing the border the driver should stop and exit SH mode to force the level transition. Stop-if-in-SH balises could be placed at some distance in advance of the border to mitigate the risk of not stopping.

4.2.20.4 This topic is project specific and is not considered in chapter 5.

#### **4.2.21 Geographical position after ETCS border**

4.2.21.1 When using the geographical position function and if after the ETCS border no geographical position information is sent to the train, e.g. if RBC is used to send geographical position and due to disconnecting after level transition, the function should be switched off. As it could occur that the connection with the RBC is interrupted before, it is recommended to switch this function off at least also by information from a balise group to prevent wrong information.

#### **4.2.22 Location ETCS border**

4.2.22.1 Although optical signals are project specific the location of the border signal and the ETCS border could be strongly related. Especially if the border signal is close to the ETCS border, i.e. just before, at or shortly after the border. If the border is in the middle of a signal block the relation is less important.

4.2.22.2 When considering the location of the ETCS border the national system behavior should be taken into account. E.g. is the national system a continuous or spot based system, what kind of protection is used for signal passed at danger and what kind of operational procedures are needed for passing a signal at danger. This issue is considered in section 5.2.2.2.

## **5. Recommended solutions**

### **5.1 Level Transition Announcement and MA**

#### **5.1.1 Basic considerations**

5.1.1.1 Functional step 1 is about the process to announce the transition to level NTC and authorise the ERTMS/ETCS on-board to pass the ETCS border.

5.1.1.2 The following issues from chapter 4.2 must be considered in this functional step:

- Authorisation across the ETCS border (see 4.2.2)
- Allow level transition at line speed (see 4.2.3)
- Announcement of level transition (see 4.2.5)
- Driver acknowledgement of level transition (see 4.2.6)
- Avoid Level Transition Announcement for diverging trains (see 4.2.7)
- Manual cancellation of the route from the ETCS border (see 4.2.8)
- Start of mission in rear of the ETCS border (see 4.2.9)
- Approaching the border in SR mode (see 4.2.17)

5.1.1.3 It is recommended to announce the transition to level NTC by RBC. The reason for this is to be flexible about when the announcement is given. If required by the national system announcement by balise is recommended to add redundancy for degraded situations to make sure that the STM is able to read information from the national system.

5.1.1.4 The announcement by balise makes it possible to have it at a specific location, e.g. to activate the STM. The announcement from the RBC makes it possible to have it depend on authorisation to pass the border and also to cover for Start-of-mission and degraded situations when the balise group giving the transition announcement is in rear of the train. But it is assumed that a balise group is the primary source of the announcement when approaching the border in SR mode when required by the national system.

5.1.1.5 It is also recommended to engineer a request for driver acknowledgement of the level transition in rear of the ETCS border, also for trains approaching the border in SR mode.

#### **5.1.2 Track layout**

TRACK LAYOUT	BG	DESCRIPTION	BG INFORMATION
	LTA	Level Transition Announcement (if needed)	Packet 41: Level Transition Order announcing the transition to level NTC at the ETCS border
	LTA2	Level Transition Cancellation (if needed)	Packet 41: Level Transition Order with immediate transition to level 2; this cancels the transition to level NTC
	LTA 2	Level Transition Announcement (if needed)	Packet 41: Level Transition Order announcing the transition to level NTC at the ETCS border
	LTO	Level Transition Order	Packet 41: Level Transition Order with immediate transition to level NTC

Table 2: Balise groups used for functional step 1

- 5.1.2.1 The LTA balise group is located at distance D1 from the ETCS border and announces the transition to level NTC. Giving the announcement by balise group allows for a precise location where the announcement is sent.
- 5.1.2.2 The distance D1 has to consider the applicable line speed together with the times shown in section 5.1.3 for evaluating the LTA, for the STM to report state Hot Standby in rear of the national infrastructure and the request for driver acknowledgement of the level transition. In case there are multiple tracks leading to the border, the distance should be calculated for each track based on this specific speed profile; in addition, see 5.3.1.2.
- 5.1.2.3 In case D1 places the LTA in rear of a diverging point, then the primary transition announcement can be made by the RBC instead and only have the redundant LTA2 after the point. This avoids announcing the transition for diverging trains. To facilitate a uniform transition process this could be a recommendation also for locations without diverging point.
- 5.1.2.3.1 Note: It is for the project to decide if a train with a failed or not connected STM should be stopped in rear of the ETCS border, i.e. this is only possible with a known STM by setting STM max speed to 0 km/h. In that case the distance D1 must include also the braking distance for the applicable train types and the time for the STM to be detected as failed when travelling at line speed.
- 5.1.2.4 After the announcement the ERTMS/ETCS on-board will make the level transition when the estimated train front reaches the indicated distance to the border or when

reading the balise group at the border. In case the transition should be performed when reading the LTO, then the Level Transition Order should announce the transition for a location in advance of the border and the LTO. This is because the estimated front end of the train depends on the accumulated odometer inaccuracy and the announced location must consider the possible inaccuracy when making the transition based on the estimated train front end somewhere near the border. This could result in a delayed transition in case the LTO balise group is not read.

5.1.2.5 The LTC balise group sends an immediate Level Transition Order to level 2 to cancel a previously received announcement to level NTC by balises and is put in tracks diverging from the ETCS border, if needed. The LTC must be located within the announced distance to the border, as otherwise the train will perform the transition after having travelled the announced distance.

5.1.2.5.1 Note: This location must also consider the accumulated odometer inaccuracy on-board the train and the LTC should be read even before the driver is requested to acknowledge the transition. For announcements made by the RBC, the RBC should cancel the transition order, but the LTC can still be used for redundancy.

5.1.2.6 The LTA2 balise group contains a transition announcement to level NTC allowing the STM to change to state Hot Standby if no other Level Transition Announcement has been received and the train is running in SR either after SoM or using Override EOA. The LTA2 is primarily foreseen for degraded situations, but it will also add redundancy to the announcement given by the LTA and increase the accuracy of the odometer. The LTA2 is only needed if the national system requires in degraded situations to read national system trackside equipment having the STM in state HS.

5.1.2.6.1 Note: In case the STM uses packet 44 and the STM is in state CS passing the LTO, e.g. by not using/reading LTA and LTA2, the national data in packet 44 sent together with the LTO is anyway used by the on-board according to SUBSET-026 [2] 4.8.1.3.

5.1.2.7 The distance D2 between the LTA2 balise group and the LTO balise group depends on the time required for the STM to reach the state HS, the SR speed and if this situation is regarded as a normal or degraded situation; in addition, see 5.3.1.2.

### 5.1.3 Sequence diagram



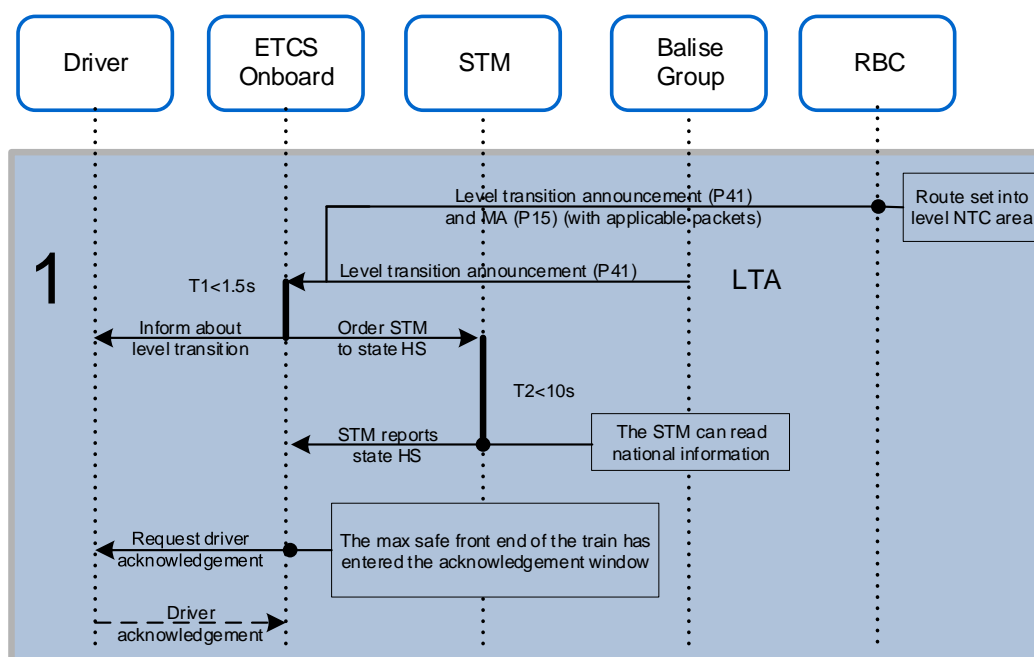

Figure 6: General sequence diagram for step 1

- 5.1.3.1 Figure 6 above shows that the announcement is given both by balise group and the RBC, but which comes first depends on the RBC conditions for giving the announcement and where the LTA balise group is placed; it could also be that an LTA2 is used instead of the LTA. It is recommended that the RBC gives the announcement together with an MA and at latest with the MA to pass the ETCS border.
- 5.1.3.2 T1 is the maximum time for the ERTMS/ETCS on-board to indicate a status change to the driver after receiving information from a balise group (see SUBSET-041 [6] 5.2.1.3) or the RBC (see SUBSET-041 [6] 5.2.1.4).
- 5.1.3.3 When receiving the announcement for transition to level NTC, the ERTMS/ETCS on-board orders the STM to state Hot Standby This must be done sufficiently in rear of the national system's infrastructure for the STM to be in state Hot Standby before it needs to read relevant national information.
- 5.1.3.4 T2 is the maximum time allowed for the STM to report that it has changed to state Hot Standby according to SUBSET-035 [3] and otherwise ERTMS/ETCS on-board will consider the STM as failed or not connected; for the consequences see 5.1.6.
- 5.1.3.5 It is recommended that the Level Transition Announcement defines a distance in rear of the transition location from where the driver is requested to acknowledge the transition to level NTC; this is the acknowledgement window. This distance is usually based on local characteristics or national requirements, e.g. on the time the driver has to prepare for applying the rules of the national system area. If this distance is not defined or if the driver does not acknowledge before the transition is performed, there is also an additional 5 seconds for acknowledgement after the transition before the brakes are applied.

#### 5.1.4 Authorisation across the ETCS border

- 5.1.4.1 The authorisation to pass the ETCS border can be implemented either as a MA including track description information and EOA inside the level NTC area, or as (STM) target speed at the ETCS border i.e. as a LOA including speed restrictions at and in advance of the ETCS border as supervised by the STM (the STM max speed can be used).
- 5.1.4.2 Both EOA and LOA require that the SSP at the ETCS border does not exceed the maximum allowed speed for the national system.
- 5.1.4.3 The EOA has the advantage that it provides the target distance and speed in the level NTC area to the driver in the DMI planning area, but it requires information (routes set, SSP, danger points, etc.) from the level NTC area.
- 5.1.4.4 Using EOA means that the train calculates the ETCS supervision limits according to the train's specific braking performance. Thus, the speed at the border supervised by ETCS can be lower or higher (see 5.1.4.2 for risk mitigation of overspeeding) than the allowed speed for the national system.
- 5.1.4.5 Using LOA has the advantage that for most situations it is sufficient to read the aspect of the signal for entering the level NTC area. However, the RBC may need to provide some track description beyond the border also for the LOA and due to variations in braking performance, the speed provided by the signal aspect may be too restrictive for good braking trains.
- 5.1.4.6 For the LOA the processing time to switch to level NTC, 1,5 seconds after reading balise group LTO, must be taken into account to prevent passing the location of the LOA before the level transition is performed as otherwise the train will be tripped.
- 5.1.4.7 Depending on the national system in use a specific speed can be required to be able to read national system information in rear of the ETCS border. This STM system speed and location can be provided by the trackside system and/or by the STM if supported; see SUBSET-035 [3]. If handled by the trackside system the SSP in the Level 2 MA shall limit the speed from the location where the national trackside equipment is installed up to the ETCS border to respect the maximum system speed of the STM. If not supported by the STM this speed limitation should be engineered in the trackside system.
- 5.1.4.8 If national train categories are used the STM can limit the maximum speed depending on the train category. The supervised speed shall not be above the allowed speed for the national system.
- 5.1.4.9 To mitigate the potential risk of entering an unlocked route after manual release of the route from the ETCS border for both LOA and EOA radio supervision should be used. If radio supervision is not used, depending on the rules and procedures in use on both sides of the border, when using LOA the MA should consider a timeout for the speed to pass the border and when using EOA the MA should have a section timer for which the stop location is in advance of the border.

- 5.1.4.10 If the authorisation to pass the ETCS border into the level NTC area is revoked it is recommended that the RBC together with shortening the movement authority also cancels the transition order to level NTC (i.e. by sending an immediate transition to level 2) to indicate to the driver that the transition is cancelled and to avoid a transition to level NTC when a route is set remaining in the level 2 area.

### **5.1.5 Alternative solution**

- 5.1.5.1 As an alternative to announce the level transition both by balise group and RBC, it is possible to give the announcement only from balise group(s). However, this means that the announcement cannot be route dependent unless using switchable balise groups, the flexibility for degraded situations is reduced and the solution is less redundant if the LTA balise group is missed. The train may also get MA to pass the border before the driver is informed about the level transition.

### **5.1.6 Degraded situations**

- 5.1.6.1 The following degraded situations are related to this functional step:

- 1) Failure to read the LTA balise group
- 2) Failure to read the LTC balise group
- 3) Failure to read the LTA2 balise group
- 4) Loss of radio contact or non-operating RBC
- 5) Failure of the STM to report state HS

- 5.1.6.2 The consequence of degraded situation 1) is that there is no announcement to level NTC sent by balise at this specific location. As a result in degraded situation, the driver may not be informed in time and the STM in state CS could be ordered directly to state DA without reading the national system. This is nominally mitigated by the announcement sent by the RBC or can be mitigated by a redundant LTA balise group, e.g. the LTA2.

- 5.1.6.3 The consequence of degraded situation 2) is that the announcement may not be cancelled for diverging routes. As a result, the train will make the transition to level NTC after travelling the announced distance to the transition location. This risk can be mitigated by only using the RBC to announce and cancel the transition order. Alternatively, a redundant balise group LTC or a duplicated balise group with only transition order for both directions can be used.

- 5.1.6.4 The consequence of degraded situation 3) is that there is no announcement to level NTC sent by balise at this specific location. In addition, that the confidence interval is not reset and thus the train may perform the transition to level NTC much earlier than expected. In most situations, the transition is already announced by the RBC or the LTA balise group, but if that is not the case then this degraded situation can be mitigated by a redundant LTA2 or, if possible, by having the RBC provide an announcement. But, as the LTA2 is itself primarily a redundant balise, the need for mitigations should be limited.

- 5.1.6.5 The consequence of degraded situation 4) is that there is no Level Transition Announcement from the RBC. In case there is also no authorisation sent to pass

the ETCS border, then the driver has to get permission to select Override EOA and continue. Depending on where the train starts towards the border, it may still receive the announcement from the LTA or LTA2 balises; otherwise, the transition to level NTC is performed when passing the LTO balise group.

5.1.6.5.1 Note: The entry in SR mode (e.g. after selecting Override EOA) deletes a Level Transition Announcement stored on-board.

5.1.6.6 The consequence of degraded situation 5) is that the ERTMS/ETCS on-board orders the STM to state Failure and sets the STM max speed to zero; see SUBSET-035 [3] 10.3.2.2, 10.3.2.4 and 10.12.1.3.

## 5.2 Level NTC Transition

### 5.2.1 Basic considerations

5.2.1.1 Functional step 2 is about the transition to level NTC. The following issue from chapter 4.2 must be considered in this functional step:

- Protect EOA in rear of the ETCS border (see 4.2.16)

### 5.2.2 Track layout

TRACK LAYOUT	BG	DESCRIPTION	BG INFORMATION
	LTO	Level Transition Order	Packet 41: Level Transition Order (immediate transition to level NTC)

Table 3: Balise groups used for functional step 2

5.2.2.1 The LTO balise group is located at the ETCS border and orders immediate transition to level NTC.

5.2.2.2 When the EOA is close to the ETCS border and, depending on the national system, it must be ensured that a train will be tripped if passing the last EOA in rear of the transition location, the ETCS border, i.e. the announced location by RBC and LTA/LTA2, and the LTO balise group shall be located at least at the maximum odometer confidence interval in advance of the last EOA in the level 2 area.

### 5.2.3 Sequence diagram

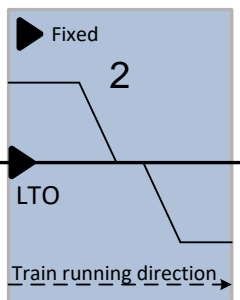
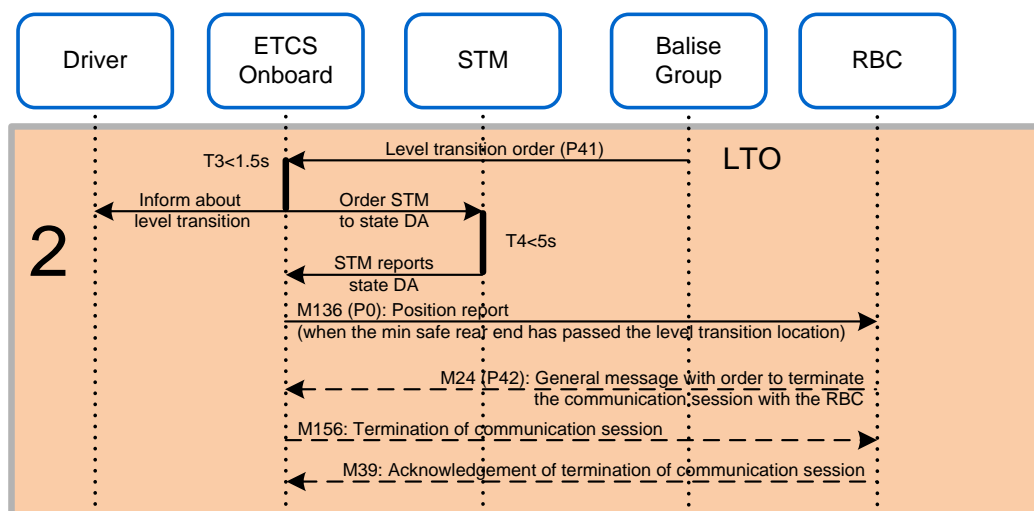

Figure 7: General sequence diagram for step 2

- 5.2.3.1 T3 is the maximum time for the ERTMS/ETCS on-board to process the information received from the LTO balise group before presenting it on the driver DMI according to SUBSET-041 [6] 5.2.1.3. The ERTMS/ETCS on-board also orders the STM to state Data Available.
- 5.2.3.2 T4 is the time within which the STM is expected to report state Data Available (see SUBSET-035 [3]), otherwise the ERTMS/ETCS on-board considers the STM as failed; for the consequences see 5.2.4.
- 5.2.3.3 The trackside engineering must consider the time T3 + T4 before ETCS takes a safe reaction (e.g. applying the brakes) after the transition location, either because the STM did not report state DA in due time or because of a command from the STM.
- 5.2.3.4 The dashed arrows in Figure 7 above shows that the RBC can send an order to terminate the communication session after receiving a position report from the ERTMS/ETCS on-board indicating that the train has left the ETCS area with its min safe rear end.
- 5.2.3.5 An open communication session in level NTC can be an issue for the RBC and/or GSM-R resources and cause undesired indications on the DMI. To mitigate the risk that the communication session remains open after leaving the ETCS area, if there is no order from the RBC to terminate the communication session (for whatever reason), this order can also be given by a balise group at the border, e.g. the LTO balise group, or in the level NTC area. After the on-board performs the transition to LNTC there could be no need any more to have contact with the non-supervising RBC.
- 5.2.3.5.1 Note: As mitigation for the issue described in CR1311 ERA/OPI/2020-2 [8] it is recommended to include the value "1" for Q\_SLEEPSESSION for all session termination orders.

## 5.2.4 Degraded situations

- 5.2.4.1 The following degraded situations are related to this functional step:
- 1) Failure to read the LTO balise group
  - 2) Failure of the STM to report state DA
- 5.2.4.2 The consequence of degraded situation 1) is that the transition to level NTC is not made for trains without an announcement, e.g. degraded situation in mode SR. This can be mitigated by repeating the information in the LTO in other balises, but the need for that is limited due to the redundancy in the announcement by balise groups and by the RBC and thus the train will anyway make the level transition. For locations where trains nominally could pass the transition location without announcement, it is recommended to mitigate this by having LTA2 balise groups.
- 5.2.4.3 The consequence of degraded situation 2) is that when the STM is detected as failed when in state HS, the on-board will order the STM to state Failure and the emergency brake is applied. The time T4 to report state DA, 5 seconds (see SUBSET-035 [3] 10.3.2.4 D16), could lead to additional requirements in the level NTC area, e.g. take into account additional time/distance that the national system is not active.

### **5.3 General Recommendations for Transition to level NTC**

#### **5.3.1 Balises**

- 5.3.1.1 The balise groups in the level NTC approach area must consist of at least two balises for the information in them to be valid in a defined direction if no linking information is available.
- 5.3.1.2 The trackside engineering may need to consider the possible location of the balise antenna (see SUBSET-040 [5] 4.1.2.2) when reading a balise group and possibly some additional delay depending on the number of balises in the group being read (see SUBSET-036 [4] 4.2.9).

#### **5.3.2 National Values**

- 5.3.2.1 The ERTMS/ETCS train entering the level NTC area should have the correct National Values stored on-board, possible for a list of different NID\_C. If different National Values are applicable on both sides of the ETCS border, e.g. different value for V\_NVSHUNT, the National Values for the level NTC area must be given at latest at the ETCS border and this can be achieved by having them in the LTO balise group. It may also be necessary to provide another set of National Values in rear of the border, e.g. the time and distance for the validity of using Override EOA to pass the ETCS border.
- 5.3.2.2 For redundancy reasons, the National Values can also be sent by the RBC, e.g. before sending any Movement Authority to the train.
- 5.3.2.2.1 Note: This does not work for trains in Sleeping mode without a communication session, so the balise group should be the primary alternative.

- 5.3.2.2.2 Note: If giving National Values for the ETCS area in a balise group in rear of the ETCS border, then the National Values may need to be changed if the train is routed away from the level NTC area.