



**EEIG ERTMS Users Group**

123-133 Rue Froissart, 1040 Brussels, Belgium

Tel: +32 (0)2 673.99.33 - TVA BE0455.935.830

Website: [www.ertms.be](http://www.ertms.be) E-mail: [info@ertms.be](mailto:info@ertms.be)

**ERTMS USERS GROUP – ENGINEERING GUIDELINE**

**71. Level transition from L2 to  
LSTM**

Reference: 15E158

Version: 3-

Date: 2024-06-28

**Modification history**

Version	Date	Modification / Description	Editor
0.A	29/06/15	Guideline taken over by the EUG. Added new risk : Restrictive mission at the border	A. Bossy
1.0	01/07/15	Official	A. Bossy
1.1	25/09/18	Chapter 4.2.13 added	Reiner Ostermeier
1.3	11/12/2018	Changes after ESG71	ESG
2.0	10/01/2019	Version 2.0	DC
2a	2023-04-19	Added EUG reference number 15E158 Formatting updated	A. Bäärnhelm
2b	2024-03-20	Corrections to document style and layout, and editorial corrections.	A. Bäärnhelm
3-	2024-06-28	Official version	EUG

## Table of Contents

1.	Introduction .....	5
1.1	Foreword .....	5
1.2	Scope and Field of Application .....	5
1.3	Document structure .....	6
2.	References and Abbreviations .....	7
2.1	Definitions.....	7
2.2	Abbreviations.....	7
2.3	References .....	8
3.	Transition from level 2 to level STM .....	9
3.1	Introduction.....	9
3.2	Functional Steps.....	9
3.3	General Track Layout .....	9
3.4	General Sequence Diagram .....	10
4.	Issues to be addressed .....	12
4.1	Introduction.....	12
4.2	Issues.....	12
4.2.1	Loss of route protection in the route from the ETCS border .....	12
4.2.2	Authorisation across the ETCS border .....	12
4.2.3	Allow level transition at line speed .....	12
4.2.4	Avoid contradiction between line side and cab signalling .....	13
4.2.5	Announcement of level transition .....	13
4.2.6	Driver acknowledgement of level transition.....	13
4.2.7	Avoid transition announcement for diverging trains.....	14
4.2.8	Manual cancellation of the route from the ETCS border.....	14
4.2.9	Start of mission in rear of the ETCS border.....	14
4.2.10	Allow transition with On-sight routes to and/or from the ETCS border .....	14
4.2.11	Minimise the use of switchable balises.....	15
4.2.12	Management of TSRs in the area in advance of the ETCS border .....	15
4.2.13	Management of speed restrictions beginning in rear of the ETCS border.....	15
4.2.14	Management of National Values .....	17
4.2.15	Manual level selection in rear of the ETCS border .....	17
4.2.16	Protect EOA in rear of the ETCS border .....	17

4.2.17	Approaching the border in SR mode .....	17
4.2.18	Restrictive mission at the level transition.....	18
4.2.19	Level transition with STM not present and no other levels are admitted .....	18
5.	Recommended solutions.....	20
5.1	Level transition announcement and MA.....	20
5.1.1	Basic considerations .....	20
5.1.2	Track layout .....	20
5.1.3	Sequence diagram.....	22
5.1.4	Authorisation across the ETCS border .....	23
5.1.5	Alternative solution .....	24
5.1.6	Degraded situations .....	24
5.2	Level STM Transition.....	25
5.2.1	Basic considerations .....	25
5.2.2	Track layout .....	25
5.2.3	Sequence diagram.....	26
5.2.4	Degraded situations .....	27
5.3	General Recommendations for Transition to level STM .....	27
5.3.1	Balises .....	27
5.3.2	National Values.....	27

## **1. Introduction**

### **1.1 Foreword**

- 1.1.1.1 The procedure for level transitions is defined technically in chapter 5 of the SRS (see SUBSET-026 [2] and SUBSET-108 [7]) and operationally the harmonised ERTMS rules apply (see OPE TSI [1]) in addition to national rules. The procedures possible for transitions from level 2 to level STM are very flexible and currently there are many different ERTMS implementations dealing with this issue.
- 1.1.1.2 The aim of this document is to define a set of recommended trackside solutions for the engineering of transitions from an area only equipped for level 2 to level STM for the benefit of future ERTMS projects. The objective is to support an efficient and safe implementation of ERTMS, both from a technical and operational point, simplifying and harmonising future system implementations taking advantage of the experience obtained from projects already in operation.
- 1.1.1.3 This guideline is part of a bundle of guidelines with the Overall ETCS guideline [9] being the main guideline which will redirect the reader to the relevant guidelines. Be aware that the Overall ETCS guideline may also include recommendations which are related to the topics addressed in this guideline.

### **1.2 Scope and Field of Application**

- 1.2.1.1 This document is based on ERTMS/ETCS Baseline 2 and applicable for transitions from an area only equipped with ETCS level 2 to an area only equipped with level STM. Possible compatibility issues with Baseline 3 and ERA/OPI/2017-2 [8] are out of scope of this guideline.
- 1.2.1.2 Some ERTMS functions, controls or information are considered out of scope of this document because they are not directly related to the transition procedure:
- Track conditions information is considered as general information to be sent to the train independent of the transition and thus out of scope for this document.
  - The specific national trackside equipment requirements are project specific and not part of this guideline.
  - Optical signals, e.g. for the level STM area, are project specific and out of the scope of this guideline
- 1.2.1.3 It is strongly recommended that any entity using ERTMS/ETCS follows the recommendations defined in this document.
- 1.2.1.4 This guideline is based on the requirements of SUBSET-035 [3] as far as relevant for trackside engineering.
- 1.2.1.5 Bespoke interface between EVC and the national system or the case of no interface between the national system and the EVC are out of the scope of this guideline however provisions contained in this guideline can be also used in case of customised interface.

- 1.2.1.6 This guideline is applicable for a trackside where the System Version is 1.Y.
- 1.2.1.7 However, this guideline takes into consideration the following on-board systems:
- On-board system with pure System Version 1.Y (i.e. they are not fitted with any other System Version)
  - On-board system supporting System Version 1.Y and 2.Y, with active System Version 1.Y when approaching the level transition

### **1.3 Document structure**

- 1.3.1.1 Chapter 1 introduces the document and defines the scope.
- 1.3.1.2 Chapter 2 provides references, terms and abbreviations used in this document.
- 1.3.1.3 Chapter 3 provides the general functional steps for transition to level STM.
- 1.3.1.4 Chapter 4 provides the criteria assessed for the recommendations.
- 1.3.1.5 Chapter 5 provides the recommendations for each functional step.

## 2. References and Abbreviations

### 2.1 Definitions

2.1.1.1 The following table includes terms and definitions which are used in the current document:

Terminology	Definition
ETCS area	The area in between ETCS borders with infrastructure for trains running in ETCS levels 1, 2 or 3
ETCS border	The location where the ETCS level is changed
Level STM approach area	The area in rear of the ETCS border to facilitate the transition to level STM
Level STM area	The area in advance of the ETCS border
On-sight route	A locked route which is not unambiguously detected free

### 2.2 Abbreviations

2.2.1.1 The following table includes acronyms and abbreviations which are used in the current document:

Abbreviation	Description
ATP	Automatic Train Protection (national systems)
BG	Balise Group
CS	STM state Cold Standby
DA	STM state Data Available
DMI	Driver Machine Interface
EOA	End of Authority
FA	STM state Failure
HS	STM state Hot Standby
LOA	Limit of authority
LTA	Balise group for Level Transition Announcement
LTC	Balise group for Level Transition Cancellation
LTO	Balise group for Level Transition Order
M	Message, e.g. M39 is ETCS message 39
MA	Movement Authority

OS	On-Sight (ETCS mode)
P	Packet, e.g. P41 is ETCS packet 41
RBC	Radio Block Centre
SoM	Start-of-Mission; procedure for start-up of an ERTMS/ETCS train
SR	Staff Responsible (ETCS mode)
SSP	Static Speed Profile
STM	Specific Transmission Module (for national ATP systems)
TSR	Temporary Speed Restriction

## 2.3 References

2.3.1.1 The following documents and versions apply:

Ref. N°	Document Reference	Title	Version
[1]	TSI OPE	Annex A, TSI OPE, 2012/464/EC, ERTMS rules and Principles	2
[2]	SUBSET-026	ERTMS/ETCS Class 1 System Requirements Specification	2.3.0
[3]	SUBSET-035	Specific Transition Module FFFIS	2.1.1
[4]	SUBSET-036	FFFIS for Eurobalise	2.4.1
[5]	SUBSET-040	Dimensioning and Engineering rules	2.0.0
[6]	SUBSET-041	Performance Requirements for Interoperability	2.1.0
[7]	SUBSET-108	Interoperability-related consolidation on TSI annex A documents	1.2.0
[8]	ERA/OPI/2017-2	Opinion of the European Union Agency for Railways to the European Commission regarding CCS TSI Error Corrections	2017-02-04
[9]	22E087	Overall ETCS	1-



### 3. Transition from level 2 to level STM

#### 3.1 Introduction

3.1.1.1 This chapter intends to give a general overview of how to perform a transition from level 2 to level STM and can be used as a reference for the issues discussed in chapter 4. The track layout and sequence diagram presented here are further detailed in chapter 5, as applicable for each functional step.

#### 3.2 Functional Steps

3.2.1.1 In order to facilitate the recommendations detailed in chapter 5, the transition to level STM is divided into the following functional steps:

- 1) Level transition announcement and MA
- 2) Level STM transition

#### 3.3 General Track Layout

3.3.1.1 Figure 1 shows the general and relevant track design and balise groups needed to perform the different functional steps of the transition from level 2 to level STM listed in paragraph 3.2.1.1.

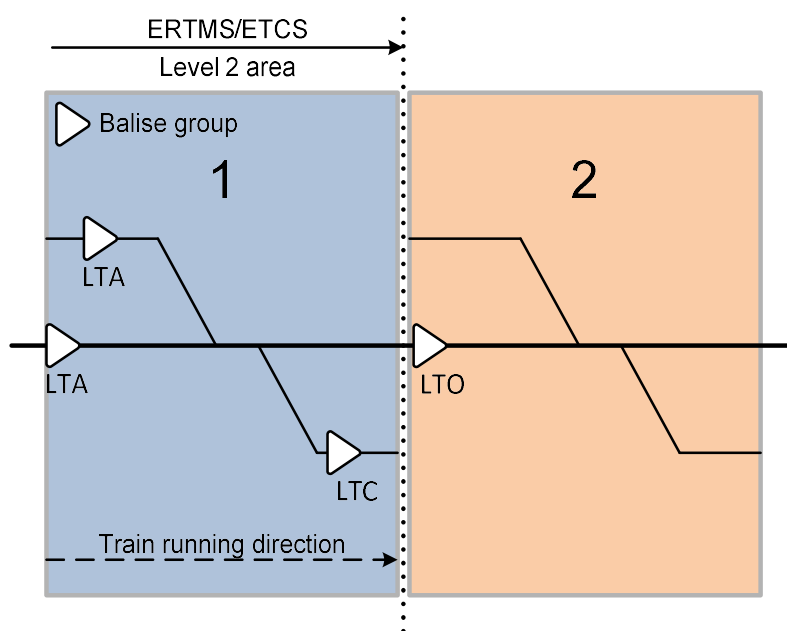

Figure 1 : Generic track layout for transition from level 2 to level STM

3.3.1.2 There are intentionally no signals shown in Figure 1 as they are not relevant for the transition procedure as such from a technical point of view.

3.3.1.3 Table 1 below represents the balise groups and information (in ETCS packets) needed for each functional step to succeed with a transition from level 2 to level STM. Optional and alternative balise groups and packets will be suggested in chapter 5.

BG	BG DESCRIPTION	BG INFORMATION (ETCS PACKETS)
LTA	Level Transition Announcement	Packet 41: Level Transition Order announcing the transition to level STM at the ETCS border
LTC	Level Transition Cancellation	Packet 41: Level Transition Order with immediate transition to level 2; this cancels the announced transition to level STM
LTO	Level Transition Order	Packet 41: Level Transition Order with immediate transition to level STM

Table 1: Balise groups for transition from level 2 to level STM

- 3.3.1.4 The information in the balise groups in the figures is only valid in the indicated train running direction, unless defined otherwise.
- 3.3.1.5 The balise group LTA announces the transition to level STM; this is also done by the RBC and the conditions for doing that are described in chapter 5.
- 3.3.1.6 The LTC balise group cancels the transition in case the train is routed away from the ETCS border after the level transition announcement has been received.
- 3.3.1.7 The LTO balise group is located at the ETCS border and orders the immediate transition to level STM.

### 3.4 General Sequence Diagram

- 3.4.1.1 The sequence diagram in Figure 2 shows the relevant information that is exchanged between the main actors when performing the transition to level STM according to the functional steps listed in 3.2.1.1 above.

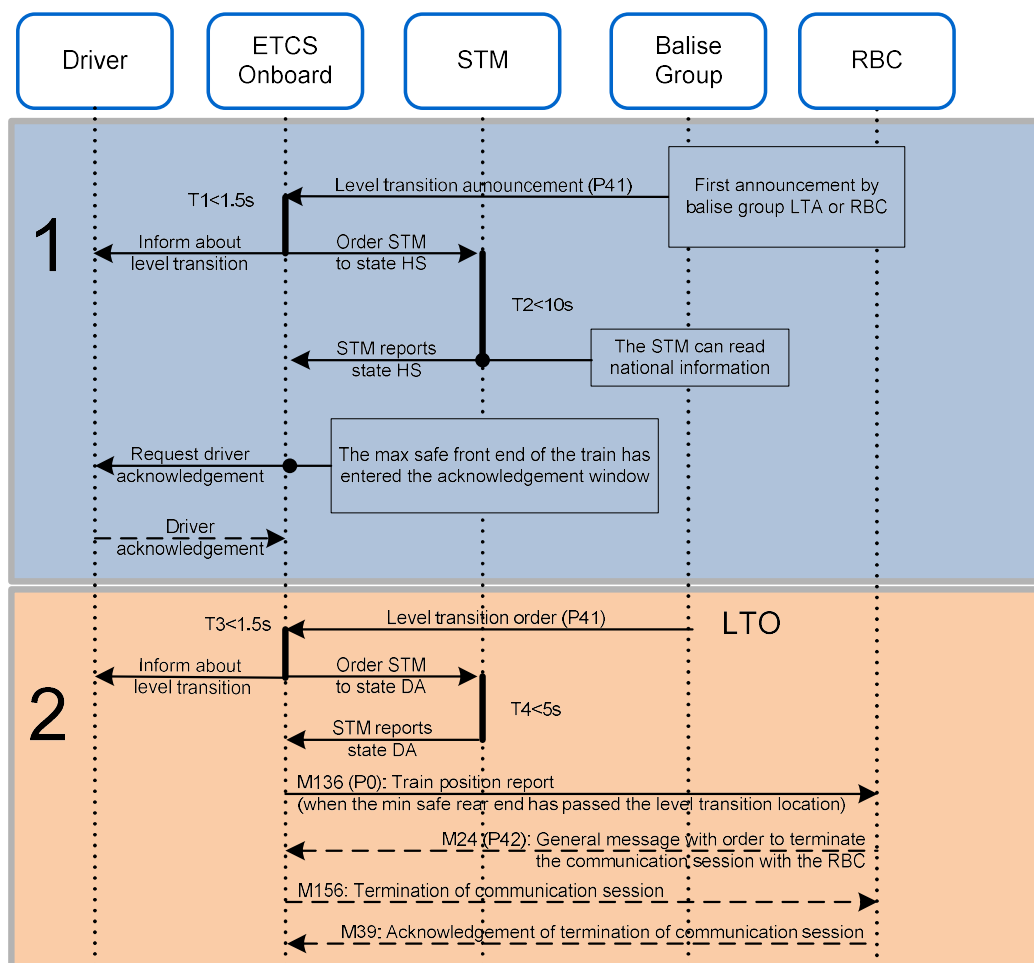

Figure 2: General sequence diagram for transition from Level 2 to level STM

- 3.4.1.2 The level transition announcement is given both by RBC and balise group LTA. The actual sequence depends on conditions which are detailed in 5.1.
- 3.4.1.3 The above diagram does not represent all information exchanged by the relevant actors but defines in general the different functional steps that are considered in this document.
- 3.4.1.4 The arrow for driver acknowledgement is 'dashed' as it is not absolutely needed because the level transition will take place also without it. The driver can acknowledge before the level transition is executed (from the location specified in the transition announcement) or within 5 seconds after the transition (see SUBSET-026 [2] 5.10.4.2); i.e. in step 1 or 2.
- 3.4.1.5 Step 1 ends and step 2 starts when the LTO balise group is read.
- 3.4.1.6 The arrows for terminating the communication session, M24, M156 and M39 are 'dashed' because they are not important for the transition as such.

## **4. Issues to be addressed**

### **4.1 Introduction**

4.1.1.1 This chapter lists the issues that need to be considered for the transition from level 2 to level STM and some of them are further detailed in the recommended solutions given in chapter 5. The issues that are not part of the recommended solutions are mentioned in this chapter because projects may still need to consider them.

### **4.2 Issues**

#### **4.2.1 Loss of route protection in the route from the ETCS border**

4.2.1.1 There must be a safe reaction in case of failure of one or more supervised conditions aiming to protect the route in advance of the ETCS border (e.g. unexpected track occupation).

4.2.1.2 The system that detects the loss of route protection is responsible to take action to resolve the hazardous situation, e.g. by informing the adjacent RBC and the national system to try to stop an affected train. The RBC can then withdraw the authorisation it has given for entering the level STM area by sending a shortened MA or an Emergency Stop message.

4.2.1.3 There is no direct impact on the transition procedure, only on the possibility to approach and pass the ETCS border. Thus, this issue is not further considered in chapter 5.

#### **4.2.2 Authorisation across the ETCS border**

4.2.2.1 The authorisation into the level STM area can be implemented with a level 2 MA with EOA in the level STM area or with LOA at the border, both considering speed restrictions (e.g. TSRs) in the level STM area relevant for calculating safe supervision limits and the braking curves used by ETCS and the national system.

4.2.2.2 The allowed ETCS speed at the level transition location must not exceed the speed allowed in the level STM area. This speed and location can be provided by the trackside system and/or STM if supported (see SUBSET-035 [3]). The allowed speed in the level STM area may also depend on national train categories.

4.2.2.3 The authorisation across the ETCS border is considered in section 5.1.4.

#### **4.2.3 Allow level transition at line speed**

4.2.3.1 Trains approaching the level STM area should not face speed restrictions caused by the transition procedure to level STM, but depending on the STM in use it may be necessary to reduce the speed to be able to read national system information in rear of the ETCS border and this is considered in section 5.1.4.

4.2.3.2 This may also be an engineering issue for the first block in advance of the ETCS border if a level 2 MA is used with an EOA in the level STM area because the speed supervision in the ERTMS/ETCS on-board may be more restrictive than

that of the national system. Thus, it might not be possible to approach the ETCS border at the line speed allowed in level STM area unless the first block section in the level STM area is long enough.

4.2.3.3 This issue is not further considered in chapter 5 as the decision for which situations the level transition should be possible at line speed is project specific.

#### **4.2.4 Avoid contradiction between line side and cab signalling**

4.2.4.1 Unclear or overlapping responsibilities of two signalling systems can give different and contradicting signalling information to the driver. This could be caused by different delays, different signalling principles (e.g. cab signalling, speed signalling / distance to go, different track information, different odometers, etc.).

4.2.4.2 This issue is avoided by synchronisations of the involved signalling systems or a clear split of responsibility at the ETCS border.

4.2.4.3 This issue is project specific and has no impact on the transition procedure therefore it is not further considered in chapter 5.

#### **4.2.5 Announcement of level transition**

4.2.5.1 The announcement to level STM must provide both the driver and the STM with enough time to prepare for the level transition. This is considered in section 5.1.

4.2.5.2 According to the ERTMS rules in OPE TSI [1], the driver shall apply national rules when the announcement to level STM is shown.

#### **4.2.6 Driver acknowledgement of level transition**

4.2.6.1 The driver will be requested to acknowledge the transition to level STM, except if the on-board is in non-leading (NL) mode. This request to acknowledge can appear either at a certain distance in rear of the ETCS border (if specified in the level transition announcement) or when switching the level.

4.2.6.2 According to the ERTMS rules in the OPE TSI [1], the driver shall apply national rules when the announcement to level STM is shown. Thus, the acknowledgement distance should give the driver time to prepare for the transition according to national rules (e.g. time to observe the optical signal to prepare to switch from cab signalling to lineside signals).

4.2.6.3 The acknowledgement distance in rear of the border can be determined from the time considered acceptable for the driver before making the transition. This time shall consider the line speed and that the announcement must be transmitted in rear of the required acknowledgement distance/time, including the required processing time of the level transition announcement. If the driver is not required to acknowledge in rear of the border, the distance is set to zero.

4.2.6.4 When requested to acknowledge, the driver should do so within 5 seconds after making the transition, as otherwise the train will be braked; see SUBSET-026 [2] 5.10.4.2.

4.2.6.5 This issue is considered in section 5.1 together with the announcement, i.e. in functional step 1, even if the driver may acknowledge in step 2.

#### **4.2.7 Avoid transition announcement for diverging trains**

4.2.7.1 Vehicles moving in the level STM approach area should not receive a level transition announcement (which has to be displayed to the driver) or be forced to make a level transition unless they are routed into the level STM area.

4.2.7.2 This problem can be avoided if the level 2 system only announces the level transition if the train is routed into the level STM area, but it may be necessary to announce the transition also for trains that will finally not enter the level STM area if the STM is required to read information from the national system infrastructure already in rear of the location of the last diverging route.

4.2.7.3 If the announcement cannot be avoided for diverging trains, it must be cancelled before the level transition is performed by the ERTMS/ETCS on-board and preferably before the driver is requested to acknowledge the level transition.

4.2.7.4 This issue is considered in functional step 1 in 5.1).

#### **4.2.8 Manual cancellation of the route from the ETCS border**

4.2.8.1 In case the route into the level STM area is cancelled manually for operational purposes (e.g. for preferred vehicle movements, change of departure sequence, etc.), the authorisation to cross the ETCS border must be revoked. This can be achieved by an updated (shortened) Movement Authority, but only if it can be sent to the affected train.

4.2.8.2 The risk of a lost safe connection between the train and the RBC is supervised by T\_NVCONTACT, but the risk that route release is handled differently at each side of the border can be mitigated by using section timers. Values for section timers must be dimensioned considering the interlocking route release timers in the applicable area.

4.2.8.3 This issue is considered in section 5.1.4.

#### **4.2.9 Start of mission in rear of the ETCS border**

4.2.9.1 ERTMS/ETCS trains always have the possibility to perform start-of-mission in the area in rear of the ETCS border, but the selection of ETCS level(s) is limited by a table of priority of trackside supported levels if available on-board the train. This table is assumed to contain only the applicable level, therefore the train is assumed to start in level 2 in rear of the ETCS border and having any other level in the table would create a mixed level area which is out of scope for this guideline.

4.2.9.2 After start of mission, the transition announcement to level STM can be given with the level 2 MA to cross the border. If no level 2 MA can be given into the level STM area, the transition to level STM can be performed in SR mode.

4.2.9.3 This issue is considered in section 5.1.

#### **4.2.10 Allow transition with On-sight routes to and/or from the ETCS border**

- 4.2.10.1 The possibility for the RBC to inform a train approaching the ETCS border that there is an On-sight route from the border, depends on the information available from the systems in that area. In case the RBC can inform the train about such an On-sight route, this could result in simultaneous requests for driver acknowledgement, one for the level transition and one for the entry in OS mode.
- 4.2.10.2 To avoid confusion on requested acknowledgements with an On-sight route starting at the ETCS border, separation between the acknowledgement windows for the level transition and the OS mode should be considered.
- 4.2.10.3 Considerations on On-sight routes in the level STM area are project specific because of the possibility to get such information and therefore not further detailed in chapter 5.
- 4.2.10.4 There is no issue with an On-sight route to the ETCS border as this is part of the MA to approach the border.

#### **4.2.11 Minimise the use of switchable balises**

- 4.2.11.1 Switchable balises should be avoided due to the extra costs compared with a fixed balise, but there are cases where they can be useful.
- 4.2.11.2 The transition to level STM can be achieved using only fixed balises and the balises in the recommendations in chapter 5 are fixed unless explicitly stated to be switchable for a well-defined purpose.

#### **4.2.12 Management of TSRs in the area in advance of the ETCS border**

- 4.2.12.1 The systems on both sides of the ETCS border must take into account speed restrictions having an impact on the train speed profile. It is possible to transmit TSRs from the RBC and/or balise groups.
  - 4.2.12.1.1 Note: Braking curves may differ between ERTMS/ETCS and the national Class B.
- 4.2.12.2 A temporary speed restriction in advance of the ETCS border, i.e. within the level STM area, known by the RBC and sent to the train, allows this speed reduction to be taken into consideration by the train before entering the level STM area. Even if the national system is installed in rear of the ETCS border, TSRs located in advance of the ETCS border (in the level STM area) may only be read by the STM in state Hot Standby and supervised when in state Data Available. The fact that STM is in Hot Standby in rear of the location where the national infrastructure is installed must be taken into account for the level transition announcement.
- 4.2.12.3 This issue has no further impact on the transition procedure and is not considered in chapter 5.

#### **4.2.13 Management of speed restrictions beginning in rear of the ETCS border**

- 4.2.13.1 In a ETCS level 2 area the driver observes only cab signalling and must not observe most line side signals. In a pure level 2 area no line side signals for speed restrictions are installed. Due to lack of harmonized rule in the OPE TSI [1], the driver must observe line side signals according to national operational rules for

instance if the level transition to level STM is announced or if the driver has acknowledged the level transition.

- 4.2.13.2 If a speed restriction is beginning in rear of the ETCS border in level 2 and ending in advance of the ETCS border in the level STM for the minimum safe front end, the driver might have not observed the line side signal for the speed restriction in level 2 (see 4.2.13.1 and 4.2.13.5) and is therefore not aware of the still relevant speed restriction in the level STM area. Even if the train exits level 2 with the correct speed restriction, the driver might accelerate the train before the minimum safe rear end has passed the end of the speed restriction. The following possible solutions could solve this issue.
- 4.2.13.3 The STM should supervise speed restrictions in level STM until the minimum safe rear end has passed the end of the speed restriction. National trackside STM infrastructure for the relevant speed restrictions should be placed in rear of the ETCS border in the level 2 area or at the ETCS border. This is valid if the STM train device fulfils the STM state HS requirements in SUBSET-035 [3].
- 4.2.13.4 Additional line side signals for the speed restriction may be repeated at the ETCS border, so that the driver can observe the speed restriction in level STM area. This is only an operational solution and might not be sufficient for national safety requirements.
- 4.2.13.5 These solutions might not be possible for route depending speed restrictions in rear of the ETCS border and diverging routes to level STM because of points. In addition, in this situation the level announcement might be sent quite late if the route is set to level STM area and the train has already passed the relevant speed restriction line side signal.
- 4.2.13.6 To avoid this situation a possible solution is to plan a distance of at least the maximum train length between the location where a speed limit (e.g. speed at point or TSR) changes and the level transition to level STM as depicted in Figure 3.

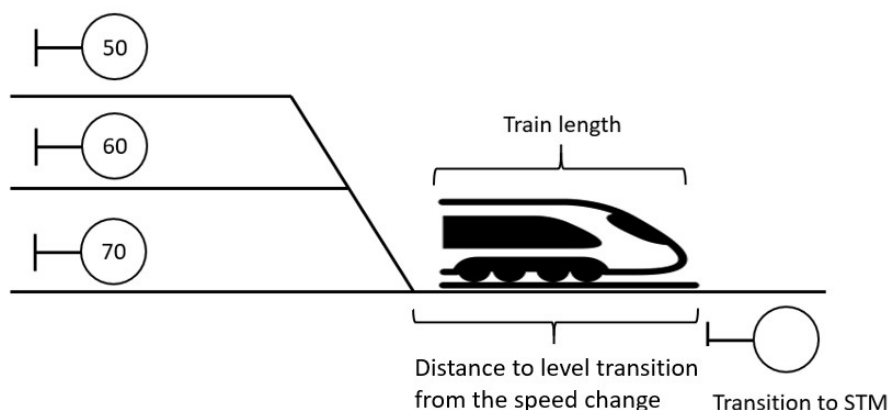

Figure 3: Train length shall be smaller than the distance to the level transition point

- 4.2.13.7 As possible alternative solution, the RBC could send a text message with the still relevant speed restriction (either relevant for train front end or for train rear end,



depending on the end of the speed restriction), if the level transition to level STM is announced.

4.2.13.8 This issue is project specific and is not considered in chapter 5.

#### **4.2.14 Management of National Values**

4.2.14.1 The ERTMS/ETCS train that exits the ETCS area should have the correct National Values stored on-board for the level STM area. This can be achieved, also for ERTMS/ETCS on-board units that cannot receive them from the RBC (e.g. in SL mode), by transmitting them from a balise group (see section 5.3).

#### **4.2.15 Manual level selection in rear of the ETCS border**

4.2.15.1 The train driver may manually select level when the train is at standstill. In case level STM is available for manual selection (in the table of trackside supported levels or with no table on-board), the driver could change to level STM already in rear of the border and (depending on the national system) move in the level 2 area.

4.2.15.2 This is potentially unsafe and can be avoided by using a packet 46, Conditional Level Transition Order, not including level STM in a balise group in rear of the location where the level transition is announced to avoid possible conflicts between packets 41 and 46, because the on-board behaviour is unclear in ERTMS/ETCS Baseline 2.

4.2.15.3 As the train is expected to be operated in the level applicable for the area where it is located, this issue is not further considered in chapter 5.

#### **4.2.16 Protect EOA in rear of the ETCS border**

4.2.16.1 When the EOA is close to the ETCS border there is a risk that the transition to level STM is performed before the min safe front end of the train reaches the EOA due to odometer inaccuracies and after switching to level STM the train may no longer obey its previous EOA.

4.2.16.2 This is solved by proper engineering of the ETCS border in relation to the last EOA in rear of the border and this issue is considered in section 5.2.

#### **4.2.17 Approaching the border in SR mode**

4.2.17.1 Trains may be moving in SR mode in rear of the ETCS border for various reasons, e.g. after start-of-mission or after selecting Override EOA.

4.2.17.2 Preventing trains to pass the ETCS border in SR mode is out-of-scope of this guideline as this is considered normal procedure for protecting a specific location, e.g. by using a balise group with ETCS packet 137: Stop if in SR. Thus, preventing trains to pass the border in SR is not considered in chapter 5.

4.2.17.3 Trains that are supposed to approach the ETCS border in SR mode should preferably receive a level transition announcement in rear of the border to prepare both the driver and the STM for the transition to the national system, as for normal train movements.

4.2.17.4 This issue is considered in section 5.1.

**4.2.18 Restrictive mission at the level transition**

4.2.18.1 A driver must never face a restrictive mission (stop or speed decrease) located just after the level transition to level STM without being warned at the appropriate distance ahead of the beginning of this restriction.

4.2.18.2 In particular, a train with good braking performance (dotted line in Figure 4) may not display the braking indication to the driver before the transition point. As an example, when the speed drops right after the border transition because there is a closed signal near the border transition. Due to very short braking distances, the train could approach the closed signal in overspeed.

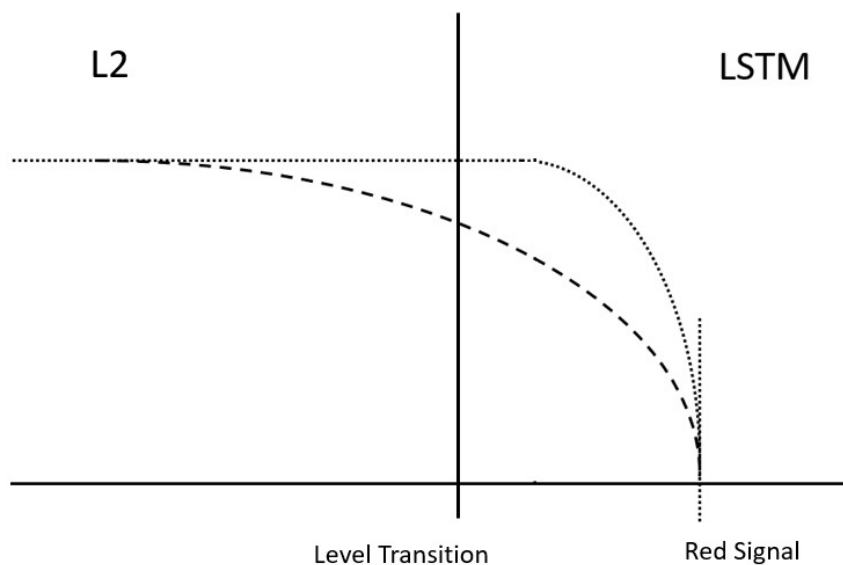

Figure 4: Train with good braking performance (dotted) and poorer braking performance (dashed)

4.2.18.3 If the DMI displays warning information received from the STM in HS state (see 10.5.2.6, 10.5.2.6.1 and 10.5.2.6.2 of SUBSET-035 [3]), when it switches to DA state, LTA and LTO BG could be located so that there is a STM wayside device in between them to warn for the restrictive mission after the LTO BG.

4.2.18.4 If the LTA BG is located ahead of the STM wayside device, a specific operational rule can be necessary to ask the driver to take into consideration the most restrictive mission among the one displayed on the DMI and the one displayed by the lateral signalling (if any) when a level transition is announced to the driver.

4.2.18.5 If the STM warning information is not displayed to the driver when the STM device switches to DA state, the protection of the speed reduction or the stop shall be ensured by an ETCS speed reduction at the level transition border.

4.2.18.6 This topic is project specific and is not considered in chapter 5.

**4.2.19 Level transition with STM not present and no other levels are admitted**

- 4.2.19.1 According to SUBSET-026 [2] chapter 5, when trackside orders a transition to a STM Level (packet 41) which is not available on-board, the OBU shall nevertheless make the transition.
- 4.2.19.2 The issue is the following: if there are no other levels in the list of the ordered level(s) in packet 41 (e.g. L0 is not allowed), the transition takes place, but train protection is not more provided unless national system is present and active (but unknown to EVC).
- 4.2.19.3 The STM not being present, no STM control function is active (i.e. no STM Max Speed).
- 4.2.19.4 In this case the OPE TSI [1] refers to non-harmonised rules.
- 4.2.19.5 According to SUBSET-026 [2] 5.10.2.6 and 5.10.2.7.1, the OBU has to indicate to the driver the new STM level showing the name of the STM which shall be stored OBU according to SUBSET-035 [3] 7.4.1.1.7
- 4.2.19.6 The trackside engineering (or route compatibility rules) should consider this issue to prevent trains from running unprotected within STM area unless national operational rules allow it.
- 4.2.19.7 This topic is project specific and is not considered in chapter 5.

## **5. Recommended solutions**

### **5.1 Level transition announcement and MA**

#### **5.1.1 Basic considerations**

5.1.1.1 Functional step 1 is about the process to announce the transition to level STM and authorise the ERTMS/ETCS on-board to pass the ETCS border.

5.1.1.2 The following issues from chapter 4.2 must be considered in this functional step:

- Authorisation across the ETCS border (see 4.2.2)
- Allow level transition at line speed (see 4.2.3)
- Announcement of level transition (see 4.2.5)
- Driver acknowledgement of level transition (see 4.2.6)
- Avoid level transition announcement for diverging trains (see 4.2.7)
- Manual cancellation of the route from the ETCS border (see 4.2.8)
- Start of mission in rear of the ETCS border (see 4.2.9)
- Approaching the border in SR mode (see 4.2.17)

5.1.1.3 It is recommended to announce the transition to level STM both by balise and by RBC. The reason for this is to be flexible about when the announcement is given and add redundancy for degraded situations to make sure that the STM is able to read information from the national system when required.

5.1.1.4 The announcement by balise makes it possible to have it at a specific location, e.g. to activate the STM. The announcement from the RBC makes it possible to have it depend on authorisation to pass the border and also to cover for Start-of-mission and degraded situations when the balise group giving the transition announcement is in rear of the train. But it is assumed that a balise group is the primary source of the announcement when approaching the border in SR mode.

5.1.1.5 It is also recommended to engineer a request for driver acknowledgement of the level transition in rear of the ETCS border, also for trains approaching the border in SR mode.

#### **5.1.2 Track layout**

TRACK LAYOUT	BG	DESCRIPTION	BG INFORMATION
	LTA	Level Transition Announcement	Packet 41: Level Transition Order announcing the transition to level STM at the ETCS border
	LTC	Level Transition Cancellation (if needed)	Packet 41: Level Transition Order with immediate transition to level 2; this cancels the transition to level STM
	LTA 2	Level Transition Announcement (if needed)	Packet 41: Level Transition Order announcing the transition to level STM at the ETCS border
	LTO	Level Transition Order	Packet 41: Level Transition Order with immediate transition to level STM

Table 2: Balise groups used for functional step 1

- 5.1.2.1 The LTA balise group is located at distance D1 from the ETCS border and announces the transition to level STM. Giving the announcement by balise group allows for a precise location where the announcement is sent.
- 5.1.2.2 The distance D1 has to consider the applicable line speed together with the times described in section 5.1.3 for evaluating the LTA, for the STM to report state Hot Standby in rear of the national infrastructure and the request for driver acknowledgement of the level transition. In case there are multiple tracks leading to the border, the distance should be calculated for each track based on this specific speed profile; in addition, see 5.3.1.2.
- 5.1.2.3 In case D1 places the LTA in rear of a diverging point, then the primary transition announcement can be made by the RBC instead and only have the redundant LTA2 after the point. This avoids announcing the transition for diverging trains.
- 5.1.2.3.1 Note: It is for the project to decide if a train with a failed or not connected STM should be stopped in rear of the ETCS border. In that case the distance D1 must include also the braking distance for the applicable train types and the time for the STM to be detected as failed when travelling at line speed.
- 5.1.2.4 After the announcement the ERTMS/ETCS on-board will make the level transition when the estimated train front reaches the indicated distance to the border or when reading the balise group at the border. In case the transition should be performed when reading the LTO, then the level transition order should announce the transition for a location in advance of the border and the LTO. This is because the

estimated front end of the train depends on the accumulated odometer inaccuracy and the announced location must consider the possible inaccuracy when making the transition based on the estimated train front end somewhere near the border. This could result in a delayed transition in case the LTO balise group is not read.

5.1.2.5 The LTC balise group sends an immediate level transition order to level 2 to cancel a previously received announcement to level STM and is put in tracks diverging from the ETCS border, if needed. The LTC must be located within the announced distance to the border, as otherwise the train will perform the transition after having travelled the announced distance.

5.1.2.5.1 Note: This location must also consider the accumulated odometer inaccuracy on-board the train and the LTC should be read even before the driver is requested to acknowledge the transition. For announcements made by the RBC, the RBC could also revoke the transition order, but the LTC can still be used for redundancy.

5.1.2.6 The LTA2 balise group contains a transition announcement to level STM allowing the STM to change to state Hot Standby if no other level transition announcement has been received and the train is running in SR either after SoM or using Override EOA. The LTA2 is primarily foreseen for degraded situations, but it will also add redundancy to the announcement given by the LTA or the RBC and increase the accuracy of the odometer.

5.1.2.7 The distance D2 between the LTA2 balise group and the LTO balise group depends on the time required for the STM to reach the state HS, the SR speed, the requirement to read national system trackside equipment when the STM is in state HS and if this situation is regarded as a normal or degraded situation; in addition see 5.3.1.2.

**5.1.3 Sequence diagram**

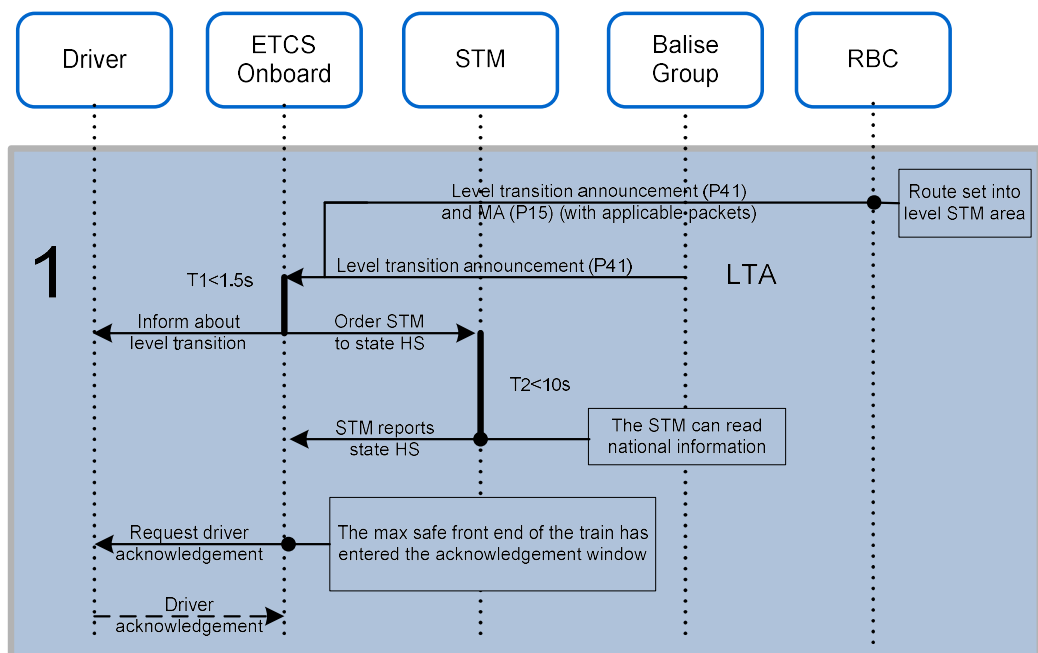

Figure 5: General sequence diagram for step 1

- 5.1.3.1 Figure 5 above shows that the announcement is given both by balise group and the RBC, but which comes first depends on the RBC conditions for giving the announcement and where the LTA balise group is placed; it could also be that an LTA2 is used instead of the LTA. It is recommended that the RBC gives the announcement together with an MA and at latest with the MA to pass the ETCS border.
  - 5.1.3.2 T1 is the maximum time for the ERTMS/ETCS on-board to indicate a status change to the driver after receiving information from a balise group (see SUBSET-041 [6] 5.2.1.3) or the RBC (see SUBSET-041 [6] 5.2.1.4).
  - 5.1.3.3 When receiving the announcement for transition to level STM, the ERTMS/ETCS on-board orders the STM to state Hot Standby This must be done sufficiently in rear of the national system's infrastructure for the STM to be in state Hot Standby before it needs to read relevant national information.
  - 5.1.3.4 T2 is the maximum time allowed for the STM to report being in state Hot Standby (HS) according to SUBSET-035 [3] and otherwise ERTMS/ETCS on-board will consider the STM as failed or not connected; for the consequences see 5.1.6.
  - 5.1.3.5 It is recommended that the level transition announcement defines a distance in rear of the transition location from where the driver is requested to acknowledge the transition to level STM; this is the acknowledgement window. This distance is usually based on local characteristics or national requirements, e.g. on the time the driver has to prepare for applying the rules of the national system area. If this distance is not defined or if the driver does not acknowledge before the transition is performed, there is also an additional 5 seconds for acknowledgement after the transition before the brakes are applied.
- 5.1.4 Authorisation across the ETCS border**
- 5.1.4.1 The authorisation to pass the ETCS border can be implemented either as a MA including track description information and EOA inside the level STM area, or as (STM) target speed at the ETCS border i.e. as a LOA including speed restrictions at and in advance of the ETCS border as supervised by the STM (the STM max speed can be used).
  - 5.1.4.2 Both EOA and LOA require that the SSP at the ETCS border does not exceed the maximum allowed speed for the national system.
  - 5.1.4.3 The EOA has the advantage that it provides the target distance and speed in the level STM area to the driver in the DMI planning area, but it requires information (routes set, SSP, danger points, etc.) from the level STM area.
  - 5.1.4.4 Using EOA means that the train calculates the ETCS supervision limits according to the train's specific braking performance and possibly with a proprietary braking model. Thus, the speed at the border supervised by ETCS can be lower than the allowed speed for the national system.

- 5.1.4.5 Using LOA has the advantage that for most situations it is sufficient to read the aspect of the signal for entering the level STM area. However, the RBC may need to provide some track description beyond the border also for the LOA and due to variations in braking performance, the speed provided by the signal aspect may be too restrictive for good braking trains.
- 5.1.4.6 For the LOA the processing time to switch to level STM, 1,5 seconds after reading balise group LTO, must be taken into account to prevent passing the location of the LOA before the level transition is performed as otherwise the train will be tripped.
- 5.1.4.7 Depending on the STM in use a specific speed can be required to be able to read national system information in rear of the ETCS border. If required, this STM system speed and location must be provided by the trackside system and/or STM if supported; see SUBSET-035 [3]. If handled by the trackside system the SSP in the level 2 MA shall limit the speed from the location where the national trackside equipment is installed up to the ETCS border to respect the maximum system speed of the STM.
- 5.1.4.8 If national train categories are used the STM can limit the maximum speed depending on the train category. The supervised speed shall not be above the allowed speed for the national system.
- 5.1.4.9 To mitigate the potential risk of entering an unlocked route after manual release of the route from the ETCS border, depending on the rules and procedures in use on both sides of the border, when using LOA the MA should consider a timeout for the speed to pass the border and when using EOA the MA should have a section timer for which the stop location is in advance of the border.
- 5.1.4.10 If the authorisation to pass the ETCS border into the level STM area is revoked it is recommended that the RBC also revokes the transition order to level STM (i.e. by sending an immediate transition to level 2) to indicate to the driver that the transition is cancelled and to avoid a transition to level STM when a route is set remaining in the level 2 area.

### **5.1.5 Alternative solution**

- 5.1.5.1 As an alternative to announce the level transition both by balise group and RBC, it is possible to give the announcement only from balise group(s). But, this means that the announcement cannot be route dependent unless using switchable balise groups, the flexibility for degraded situations is reduced and the solution is less redundant if the LTA balise group is missed. The train may also get MA to pass the border before the drivers is informed about the level transition.

### **5.1.6 Degraded situations**

- 5.1.6.1 The following degraded situations are related to this functional step:
  - 1) Failure to read the LTA balise group
  - 2) Failure to read the LTC balise group
  - 3) Failure to read the LTA2 balise group



- 4) Loss of radio contact or non-operating RBC
- 5) Failure of the STM to report state HS

- 5.1.6.2 The consequence of degraded situation 1) is that there is no announcement to level STM sent by balise at this specific location. As a result, the driver may not be informed in time and the STM in state CS could be ordered directly to state DA. This can be mitigated by the announcement sent by the RBC or by a redundant LTA balise group, e.g. the LTA2.
- 5.1.6.3 The consequence of degraded situation 2) is that the announcement may not be cancelled for diverging routes. As a result, the train will make the transition to level STM after travelling the announced distance to the transition location. This risk can be mitigated by a redundant balise group LTC or alternatively by having the RBC sending a transition order to level 2 for all diverging routes to cancel any previous announcement to level STM.
- 5.1.6.4 The consequence of degraded situation 3) is that there is no announcement to level STM sent by balise at this specific location. In addition, that the confidence interval is not reset and thus the train may perform the transition to level STM much earlier than expected. In most situations, the transition is already announced by the RBC or the LTA balise group, but if that is not the case then this degraded situation can be mitigated by a redundant LTA2 or, if possible, by having the RBC provide an announcement. But, as the LTA2 is itself primarily a redundant balise, the need for mitigations should be limited.
- 5.1.6.5 Another possible consequence of degraded situation 3) is that if the LTA2 balise group includes a Packet 137, Stop if in SR, a train in SR mode is not stopped.
- 5.1.6.6 The consequence of degraded situation 4) is that there is no level transition announcement from the RBC. In case there is also no authorisation sent to pass the ETCS border, then the driver has to get permission to select Override EOA and continue. Depending on where the train starts towards the border, it may still receive the announcement from the LTA or LTA2 balises; otherwise the transition to Level STM is performed when passing the LTO balise group.
- 5.1.6.6.1 Note: The entry in SR mode (e.g. after selecting Override EOA) deletes a level transition announcement stored on-board.
- 5.1.6.7 The consequence of degraded situation 5) is that the ERTMS/ETCS on-board orders the STM to Failure state and sets the STM max speed to zero; see SUBSET-035 [3] 7.4.1.2.2, 7.4.1.2.3 and 7.4.2.2.2.

## **5.2 Level STM Transition**

### **5.2.1 Basic considerations**

- 5.2.1.1 Functional step 2 is about the transition to level STM. The following issue from chapter 4.2 must be considered in this functional step:
- Protect EOA in rear of the ETCS border (see 4.2.16)

### **5.2.2 Track layout**

TRACK LAYOUT	BG	DESCRIPTION	BG INFORMATION
	LTO	Level Transition Order	Packet 41: Level Transition Order (immediate transition to level STM)

Table 3: Balise groups used for functional step 2

5.2.2.1 The LTO balise group is located at the ETCS border and orders immediate transition to level STM.

5.2.2.2 To ensure that a train will be tripped if passing the last EOA in rear of the transition location, the ETCS border and the LTO balise group shall be located at least at the maximum odometer confidence interval in advance of the last EOA in the Level 2 area.

5.2.3 Sequence diagram

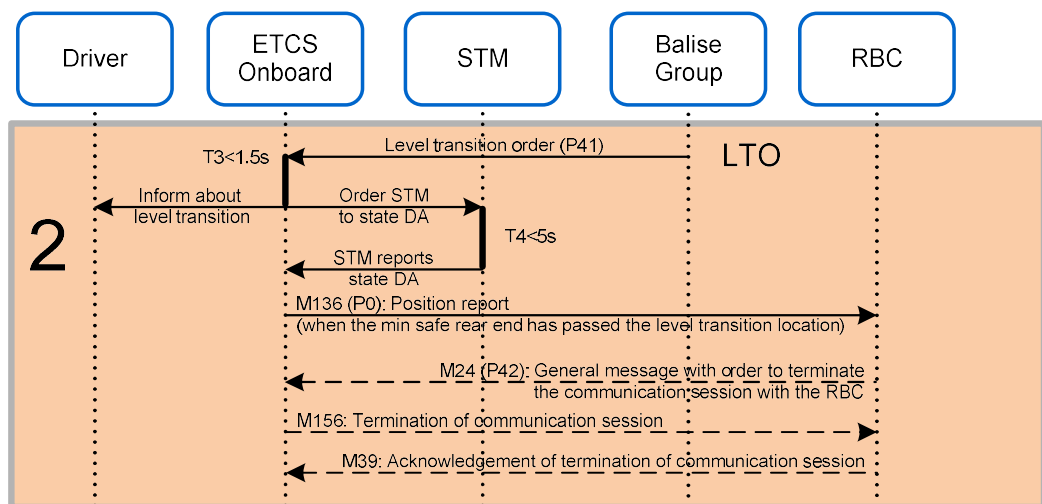

Figure 6: General sequence diagram for step 2

5.2.3.1 T3 is the maximum time for the ERTMS/ETCS on-board to process the information received from the LTO balise group before presenting it on the driver DMI according to SUBSET-041 [6] 5.2.1.3. The ERTMS/ETCS on-board also orders the STM to state Data Available (DA).

5.2.3.2 T4 is the time within which the STM is expected to report state Data Available (see SUBSET-035 [3]), otherwise the ERTMS/ETCS on-board considers the STM as failed; for the consequences see 5.2.4.

5.2.3.3 The trackside engineering must consider the time T3 + T4 before ETCS takes a safe reaction (e.g. applying the brakes) after the transition location, either because

the STM did not report DA state in due time or because of a command from the STM.

5.2.3.4 The dashed arrows in Figure 6 above shows that the RBC can send an order to terminate the communication session after receiving a position report from the ERTMS/ETCS on-board indicating that the train has left the ETCS area with its min safe rear end.

5.2.3.5 An open communication session in level STM can be an issue for the RBC and/or GSM-R resources and cause undesired indications on the DMI. To mitigate the risk that the communication session remains open after leaving the ETCS area, if there is no order from the RBC to terminate the communication session (for whatever reason), this order can also be given by a balise group in the level STM area.

## **5.2.4 Degraded situations**

5.2.4.1 The following degraded situations are related to this functional step:

- 1) Failure to read the LTO balise group
- 2) Failure of the STM to report state DA

5.2.4.2 The consequence of degraded situation 1) is that the transition to level STM is not made for trains without an announcement. This can be mitigated by repeating the information in the LTO in other balises, but the need for that is limited due the redundancy in the announcement by balise groups and by the RBC and thus the train will anyway make the level transition. For locations where trains are performing start-of-mission, it is recommended to mitigate this by having LTA2 balise groups.

5.2.4.3 The consequence of degraded situation 2) is that when the STM is detected as failed, the on-board will order the STM to Failure state and set the maximum STM speed to zero.

## **5.3 General Recommendations for Transition to level STM**

### **5.3.1 Balises**

5.3.1.1 The balise groups in the level STM approach area must consist of at least two balises for the information in them to be valid in a defined direction if no linking information is available.

5.3.1.2 The trackside engineering may need to consider the possible location of the balise antenna (see SUBSET-040 [5] 4.1.2.2) when reading a balise group and possibly some additional delay depending on the number of balises in the group being read (see SUBSET-036 [4] 4.2.9).

### **5.3.2 National Values**

5.3.2.1 The ERTMS/ETCS train entering the level STM area should have the correct National Values stored on-board, possible for a list of different NID\_C. The National Values for the level STM area must be given at latest at the ETCS border

and this can be achieved by having them in the LTO balise group. It may also be necessary to provide another set of National Values in rear of the border, e.g. the time and distance for the validity of using Override EOA to pass the ETCS border.

5.3.2.2 For redundancy reasons, the National Values can also be sent by the RBC, e.g. before sending any Movement Authority to the train.

5.3.2.2.1 Note: This does not work for trains in Sleeping mode without a communication session, so the balise group should be the primary alternative.

5.3.2.2.2 Note: If National Values for the ETCS area are given in a balise group in rear of the ETCS border, the National Values may need to be changed if the train is routed away from the level STM area.