



EEIG ERTMS Users Group
123-133 Rue Froissart, 1040 Brussels, Belgium
Tel: +32 (0)2 673.99.33 - TVA BE0455.935.830
Website: www.ertms.be E-mail: info@ertms.be

ERTMS USERS GROUP – ENGINEERING GUIDELINE

70. Level transition from L1 to LSTM

Reference: 15E157
Version: 3-
Date: 2024-06-28

Modification history

Version	Date	Modification / Description	Editor
0A	30/01/2015	First draft based on draft ERA Guideline ERA_ERTMS_040059 v0.5 (03/06/2014)	A. Meijer
0B	19/06/2015	Update based on review Sheet on V0A KKH Added New risk : Restrictive mission at the transition	A. Meijer A. Bossy
0C	01/07/2015	Update based on reviews AB, SMc	A. Meijer
1	01/07/2015	Final version	A. Meijer
1.1	25/09/2018	Chapter 4.2.12 added	Reiner Ostermeier
1.3	11/12/2018	Changes after ESG71	ESG
2.0	10/01/2019	Version 2.0	DC
2a	2023-04-19	Added EUG reference number 15E157	A. Bäärnhielm
2b	2024-03-20	Corrections to document style and layout, and editorial corrections.	A. Bäärnhielm
3-	2024-06-28	Official version	EUG

Table of Contents

1.	Introduction	5
1.1	Foreword	5
1.2	Scope and Field of Application	5
1.3	Document structure	6
2.	References and Abbreviations	7
2.1	Definitions.....	7
2.2	Abbreviations.....	7
2.3	References	8
3.	Transition from level 1 to level STM	9
3.1	Introduction.....	9
3.2	Functional Steps.....	9
3.3	General Track Layout	9
3.4	General Sequence Diagram	10
4.	Issues to be addressed	12
4.1	Introduction.....	12
4.2	Issues.....	12
4.2.1	Loss of route protection in the route from the ETCS border	12
4.2.2	Authorisation across the ETCS border	12
4.2.3	Allow level transition at line speed	12
4.2.4	Avoid contradiction between line side and cab signalling	13
4.2.5	Announcement of level transition	13
4.2.6	Driver acknowledgement of level transition.....	13
4.2.7	Avoid transition announcement for diverging trains.....	13
4.2.8	Manual cancellation of the route from the ETCS border.....	14
4.2.9	Start of mission in rear of the ETCS border.....	14
4.2.10	Allow transition with On-sight routes to and/or from the ETCS border	14
4.2.11	Management of TSRs in the area in advance of the ETCS border	15
4.2.12	Management of speed restrictions beginning in rear of the ETCS border.....	15
4.2.13	Management of National Values	16
4.2.14	Manual level selection in rear of the ETCS border	17
4.2.15	Protect EOA in rear of the ETCS border	17
4.2.16	Approaching the border in SR mode	17

4.2.17	Restrictive mission at the level transition.....	17
4.2.18	Level transition with STM not present and no other levels are admitted	18
5.	Recommended solutions.....	20
5.1	Level transition announcement and level 1 MA.....	20
5.1.1	Basic considerations	20
5.1.2	Track layout	20
5.1.3	Sequence diagram.....	22
5.1.4	Alternative solutions.....	24
5.1.5	Degraded situations	24
5.2	Level STM Transition.....	26
5.2.1	Basic considerations	26
5.2.2	Track layout	26
5.2.3	Sequence diagram.....	26
5.2.4	Alternative solutions.....	27
5.2.5	Degraded situations	27
5.3	General Recommendations for Transition to level STM.....	27
5.3.1	Authorisation across the ETCS border	27
5.3.2	Balises	28
5.3.3	National Values.....	29

1. Introduction

1.1 Foreword

- 1.1.1.1 The procedure for level transitions is defined technically in chapter 5 of the SRS (see SUBSET-026 [2] and SUBSET-108 [5]) and operationally the harmonised ERTMS rules apply (see OPE TSI [1]) in addition to national rules. The procedures possible for transitions from level 1 to level STM are very flexible and currently there are different ERTMS implementations dealing with this issue.
- 1.1.1.2 The aim of this document is to define a set of recommended trackside solutions for the engineering of transitions from an area only equipped for level 1 to level STM for the benefit of future ERTMS projects. The objective is to support an efficient and safe implementation of ERTMS, both from a technical and operational point, simplifying and harmonising future system implementations taking advantage of the experience obtained from projects already in operation.
- 1.1.1.3 This guideline is part of a bundle of guidelines with the Overall ETCS guideline [11] being the main guideline which will redirect the reader to the relevant guidelines. Be aware that the Overall ETCS guideline may also include recommendations which are related to the topics addressed in this guideline.

1.2 Scope and Field of Application

- 1.2.1.1 This document is based on ERTMS/ETCS Baseline 2 and applicable for transitions from an area only equipped with ETCS level 1 to an area only equipped with level STM. See chapter 3. Possible compatibility issues with Baseline 3 and ERA/OPI/2017-2 [10] are out of scope of this guideline.
- 1.2.1.2 Some ERTMS functions, controls or information are considered out of scope of this document because they are not directly related to the transition procedure:
- Track conditions information is considered as general information to be sent to the train independent of the transition and out of scope of this guideline.
 - The specific national trackside equipment requirements are project specific and out of scope of this guideline.
 - Location of optical signals, e.g. for the level STM area, are project specific and out of scope of this guideline.
- 1.2.1.3 It is strongly recommended that any entity using ERTMS/ETCS follows the recommendations defined in this document.
- 1.2.1.4 This guideline is based on the requirements of SUBSET-035 [3] as far as relevant for trackside engineering.
- 1.2.1.5 Bespoke interface not using STM Control function between EVC and the national system or the case of no interface between the national system and the EVC are out of the scope of this guideline.
- 1.2.1.6 This guideline is applicable for a trackside where the System Version is 1.Y.

1.2.1.7 However, this guideline takes into consideration the following on-board systems:

- On-board system with pure System Version 1.Y (i.e. they are not fitted with any other System Version)
- On-board system supporting System Version 1.Y and 2.Y

1.3 Document structure

1.3.1.1 Chapter 1 introduces the document and defines the scope.

1.3.1.2 Chapter 2 provides references, terms and abbreviations used in this document.

1.3.1.3 Chapter 3 provides the general functional steps for transition to level STM.

1.3.1.4 Chapter 4 provides the criteria assessed for the recommendations.

1.3.1.5 Chapter 5 provides the recommendations for each functional step.

2. References and Abbreviations

2.1 Definitions

2.1.1.1 The following table includes terms and definitions which are used in the current document:

Terminology	Definition
ETCS area	The area in between ETCS borders with infrastructure for trains running in ETCS levels 1, 2 or 3
ETCS border	The location where the ETCS level is changed
Level STM approach area	The area in rear of the ETCS border to facilitate the transition to level STM
Level STM area	The area in advance of the ETCS border
On-sight route	A locked route which is not unambiguously detected free

2.2 Abbreviations

2.2.1.1 The following table includes acronyms and abbreviations which are used in the current document:

Abbreviation	Description
ATP	Automatic Train Protection (national systems)
BG	Balise Group
CS	STM state Cold Standby
DA	STM state Data Available
DMI	Driver Machine Interface
EOA	End of Authority
FA	STM state Failure
HS	STM state Hot Standby
LOA	Limit of authority
LRBG	Last Relevant Balise Group
LTA	Level Transition Announcement
LTC	Level Transition Cancellation
LTO	Level Transition Order
MA	Movement Authority

P	Packet, e.g. P41 is ETCS packet 41
SoM	Start-of-Mission; procedure for start-up of an ERTMS/ETCS train
SR	Staff Responsible (ETCS mode)
SSP	Static Speed Profile
STM	Specific Transmission Module (for national ATP systems)
TSR	Temporary Speed Restriction

2.3 References

2.3.1.1 The following documents and versions apply:

Ref. N°	Document Reference	Title	Version
[1]	TSI OPE	Annex A, TSI OPE, 2012/464/EC, ERTMS rules and Principles	2
[2]	SUBSET-026	ERTMS/ETCS Class 1 System Requirements Specification	2.3.0
[3]	SUBSET-035	Specific Transition Module FFFIS	2.1.1
[4]	SUBSET-041	Performance Requirements for Interoperability	2.1.0
[5]	SUBSET-108	Interoperability-related consolidation on TSI annex A documents	1.2.0
[6]	SUBSET-040	Dimensioning and Engineering rules	2.3.0
[7]	SUBSET-036	FFFIS for Eurobalise	2.4.1
[8]	SUBSET-035	Specific Transition Module FFFIS	3.1.0 3.2.0
[9]	SUBSET-026	ERTMS/ETCS System Requirements Specifications	3.4.0 3.6.0
[10]	ERA/OPI/2017-2	Opinion of the European Union Agency for Railways to the European Commission regarding CCS TSI Error Corrections	2017-02-04
[11]	22E087	Overall ETCS	1-

3. Transition from level 1 to level STM

3.1 Introduction

3.1.1.1 This chapter intends to give a general overview of how to perform a transition from level 1 to level STM and can be used as a reference for the issues discussed in chapter 4. The track layout and sequence diagram presented here are further detailed in chapter 5 as applicable for each functional step.

3.2 Functional Steps

3.2.1.1 In order to facilitate the recommendations detailed in chapter 5, the transition to level STM is divided into the following functional steps:

- 1) Level transition announcement and MA
- 2) Level STM transition

3.3 General Track Layout

3.3.1.1 Figure 1 shows the general and relevant track design and balise groups needed to perform the different functional steps of the transition from level 1 to level STM. There could be more balises installed, or more information in the balises, but only the relevant balises and information for the transition is shown. There are intentionally no signals shown in this figure as they are not relevant for the transition procedure as such from a technical point of view.

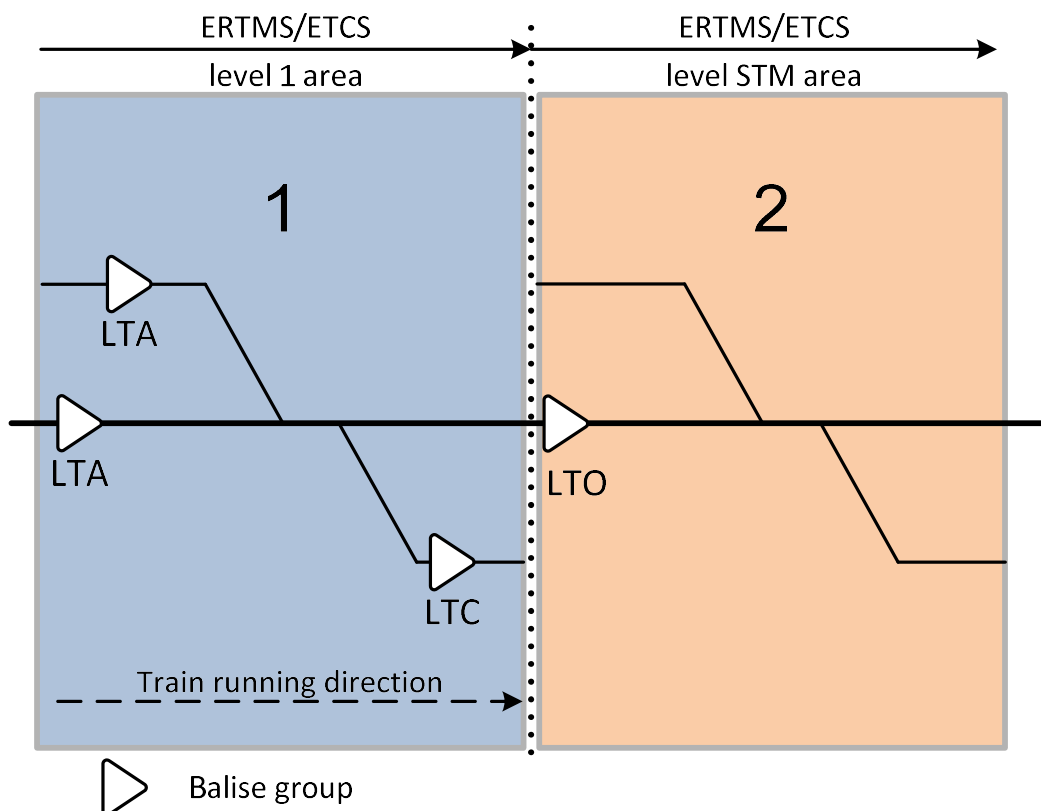

Figure 1: Generic track layout for transition from level 1 to level STM

3.3.1.2 Table 1 below represents the balise groups and information (in ETCS packets) needed for each functional step to succeed with a transition from level 1 to level STM. Optional and alternative balise groups and packets will be suggested in chapter 5.

BG	BG DESCRIPTION	BG INFORMATION (ETCS PACKETS)
LTA	Level Transition Announcement	Packet 41: Level Transition Order announcing the transition to level STM at the ETCS border
LTC	Level Transition Cancellation	Packet 41: Level Transition Order with immediate transition to level 1; this cancels the announced transition to level STM
LTO	Level Transition Order	Packet 41: Level Transition Order with immediate transition to level STM

Table 1: Balise groups for transition from level 1 to level STM

3.3.1.3 The information in the balise groups in the figures is only valid in the indicated train running direction.

3.3.1.4 The specific national trackside equipment requirements are project specific and not part of this guideline.

3.3.1.5 There is also need for a Movement Authority to pass the ETCS border, but this can be given at any location in rear of the LTO balise group, even in rear of the LTA balise group.

3.3.1.6 The LTA balise group announces the transition to level STM.

3.3.1.7 The LTC balise group cancels the transition in case the train is routed away from the ETCS border after the level transition announcement has been received.

3.3.1.8 The LTO balise group is located at the ETCS border and orders the immediate transition to level STM.

3.4 General Sequence Diagram

3.4.1.1 The following sequence diagram shows the relevant information that is exchanged between the main actors when performing the transition to level STM according to the functional steps listed in section 3.2.1.1.

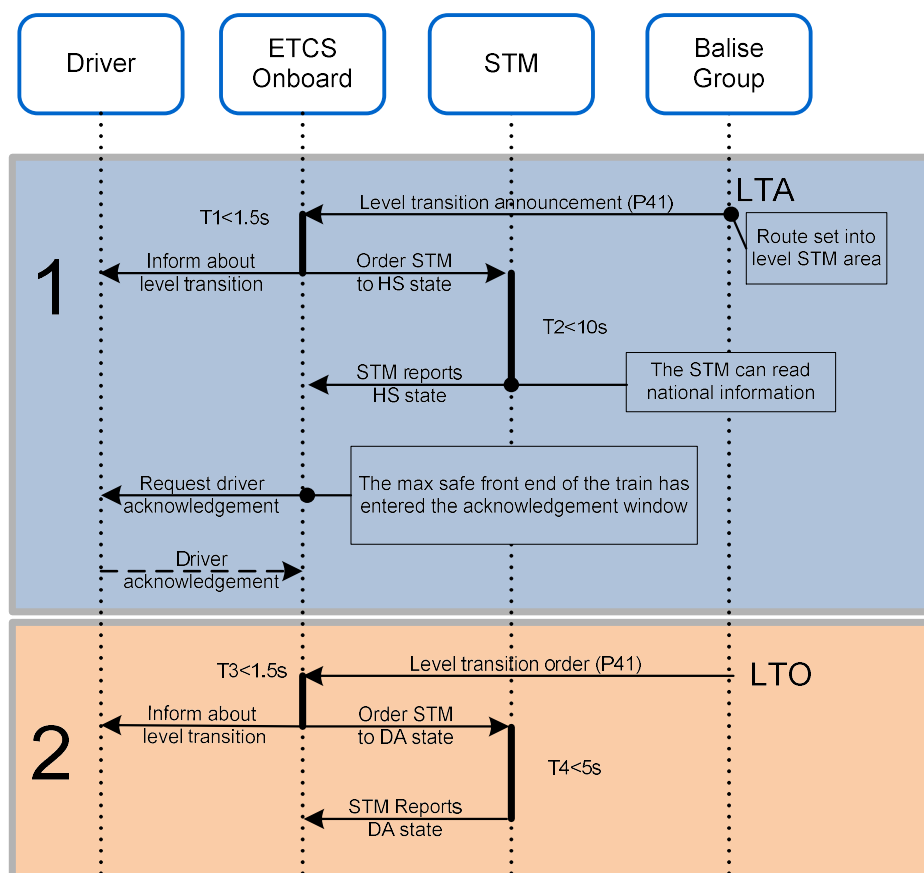

Figure 2: General sequence diagram for transition from level 1 to level STM

- 3.4.1.2 Figure 2 above does not represent all information exchanged by the relevant actors but defines in general the different functional steps that are considered in this document.
- 3.4.1.3 The arrow for driver acknowledgement is 'dashed' as it is not absolutely needed because the level transition will take place also without it. The driver can acknowledge before the level transition is executed (from the location specified in the transition announcement) or within 5 seconds after the transition (see SUBSET-026 [2] 5.10.4.2); i.e. in step 1 or 2.
- 3.4.1.4 Step 1 ends and step 2 starts when the LTO balise group is read.

4. Issues to be addressed

4.1 Introduction

4.1.1.1 This chapter lists the issues that need to be considered for the transition from level 1 to level STM and some of them are further detailed in the recommended solutions given in chapter 5. The issues that are not part of the recommended solutions are mentioned here because projects may still need to consider them.

4.2 Issues

4.2.1 Loss of route protection in the route from the ETCS border

4.2.1.1 There must be a safe reaction in case of failure of one or more conditions supervised to protect the route in advance of the ETCS border; e.g. due to unexpected track occupation or emergency stops initiated by staff or automatic systems.

4.2.1.2 The system that detects the loss of route protection is responsible to take action trying to resolve the hazardous situation for an affected train. As this may have an impact on the Movement Authority, this issue is considered in section 5.1.

4.2.2 Authorisation across the ETCS border

4.2.2.1 The authorisation into the level STM area can be implemented with a MA with EOA in the level STM area or with LOA at the border, both considering speed restrictions (e.g. TSRs) in the level STM area relevant for calculating safe supervision limits and the braking curves used by ETCS and the national system.

4.2.2.2 The allowed ETCS speed at the level transition location must not exceed the speed allowed in the level STM area. This speed and location can be provided by the trackside system and/or STM if supported (see SUBSET-035 [3]). The allowed speed in the level STM area may also depend on national train categories.

4.2.2.3 The authorisation across the ETCS border is considered in section 5.3.1.

4.2.3 Allow level transition at line speed

4.2.3.1 Trains approaching the level STM area should not face speed restrictions caused by the transition procedure to level STM, but depending on the STM in use it may be necessary to reduce the speed to be able to read national system information in rear of the ETCS border and this is considered in section 5.3.1.

4.2.3.2 This may also be an engineering issue for the first block in advance of the ETCS border if a level 1 MA is used with an EOA in the level STM area because the speed supervision in the ERTMS/ETCS on-board may be more restrictive than that of the national system. Thus, it might not be possible to approach the ETCS border at the line speed allowed in level STM area unless the first block section in the level STM area is long enough. This is not further considered in chapter 5 as the decision for which situations the level transition should be possible at line speed is project specific.

4.2.4 Avoid contradiction between line side and cab signalling

4.2.4.1 Unclear or overlapping responsibilities of two signalling systems can give different and contradicting signalling information to the driver. This could be caused by different delays, different signalling principles (e.g. cab signalling, speed signalling / distance to go, different track information, different odometers, etc.).

4.2.4.2 This issue is avoided by synchronisations of the involved signalling systems or a clear split of responsibility at the ETCS border

4.2.4.3 This issue has no impact on the transition procedure and is not further considered in chapter 5.

4.2.5 Announcement of level transition

4.2.5.1 The announcement to level STM must provide both the driver and the STM with enough time to prepare for the level transition. This is considered in section 5.1.

4.2.5.2 According to the ERTMS rules in the OPE TSI [1], the driver shall apply non-harmonised rules when the announcement to level STM is shown.

4.2.5.3 Thus, the announcement distance should give the driver time to prepare for the transition according to non-harmonised rules (e.g. time to observe the optical signal to prepare to switch from cab signalling to lineside signals) (see section 5.1.2.2).

4.2.6 Driver acknowledgement of level transition

4.2.6.1 The driver will be requested to acknowledge the transition to level STM except if the on-board is in non-leading (NL) mode. This request to acknowledge can appear either at a certain distance in rear of the ETCS border (if specified in the level transition announcement) or when switching the level.

4.2.6.2 The acknowledgement distance in rear of the border can be seen as a certain time before making the transition considering the applicable line speed and the announcement must be transmitted in rear of the required acknowledgement distance/time, including the required processing time of the level transition announcement. If the driver is not required to acknowledge in rear of the border, the distance is set to zero.

4.2.6.3 When requested to acknowledge the driver should do so within 5 seconds after making the transition, as otherwise the train will be braked; see SUBSET-026 [2] 5.10.4.2.

4.2.6.4 This issue is considered in section 5.1 together with the announcement, i.e. in functional step 1, even if the driver may acknowledge in step 2.

4.2.7 Avoid transition announcement for diverging trains

4.2.7.1 Vehicles moving in the level STM approach area should not receive a level transition announcement (which has to be displayed to the driver) or be forced to make a level transition unless they are routed into the level STM area.

4.2.7.2 This problem can be avoided if the level 1 system only announces the level transition if the train is routed into the level STM area, but it may be necessary to announce the transition also for trains that will finally not enter the level STM area if the STM is required to read information from the national system infrastructure already in rear of the location of the last diverging route.

4.2.7.3 If the announcement cannot be avoided for diverging trains then it must be cancelled before the level transition is performed by the ERTMS/ETCS on-board and preferably before the driver is requested to acknowledge the level transition.

4.2.7.4 This issue is considered in functional step 1 in section 5.1.

4.2.8 Manual cancellation of the route from the ETCS border

4.2.8.1 In case the route into the level STM area is cancelled manually for operational purposes (e.g. for preferred vehicle movements, change of departure sequence, etc.), the authorisation to cross the ETCS border must be revoked. This is commonly handled in the ETCS Level 1 sections through the relation between the ETCS timers in the MA and the existing timers in the infrastructure for this manual route release. Additionally, the level 1 MA will reflect the new EOA.

4.2.8.2 To avoid the train performing the transition to STM while not entering the level STM area, the transition order to STM must be cancelled if the authorisation to cross the transition location into the level STM area is cancelled (see also section 4.2.1, 4.2.7 and the recommendations in section 5.1).

4.2.9 Start of mission in rear of the ETCS border

4.2.9.1 ERTMS/ETCS trains always have the possibility to perform start-of-mission in the area in rear of the ETCS border, but the selection of ETCS level(s) is limited by a table of priority of trackside supported levels if available on-board the train. This table is assumed to contain only the applicable level, therefore the train is assumed to start in level 1 in rear of the ETCS border and having any other level in the table would create a mixed level area which is out of scope for this guideline.

4.2.9.2 In case the train starts in level 1 in a location where no level 1 MA can be given into the level STM area, the transition to level STM can be performed in SR mode. This issue is considered in section 5.1.

4.2.9.2.1 Note: Without an announcement of the level transition, the STM will not be able to read any information from the national system until in Hot Standby state or Data Available state. Additional measures could be necessary to cover for not being able to read national information in rear of the border and that there is some delay before being able to read information after making the transition to level STM.

4.2.9.3 The operational use of the “override EoA” function must be in line with the ERTMS rules in the OPE TSI [1] to pass an EOA. See the recommendations in section 5.1 and 5.2.

4.2.10 Allow transition with On-sight routes to and/or from the ETCS border

- 4.2.10.1 The possibility for the system to inform a train approaching the ETCS border that there is an On-sight route depend on the information from the systems in that area. In case the system can inform the train about such an On-sight route, this could result in simultaneous requests for driver acknowledgement, one for the level transition and one for the entry in OS mode.
- 4.2.10.2 To avoid confusion on requested acknowledgements with an On-sight route starting at the ETCS border, separation between the acknowledgement's windows for the level transition and the OS mode should be considered.
- 4.2.10.3 Considerations for On-sight routes in the level STM area are project specific because of the possibility to get such information and therefore not further detailed in section 5.1.
- 4.2.10.4 There is no issue with an On-sight route to the ETCS border as this is then part of the MA to approach the border.

4.2.11 Management of TSRs in the area in advance of the ETCS border

- 4.2.11.1 The systems on both sides of the ETCS border must take into account speed restrictions having an impact on the train speed profile. It is possible to transmit TSRs from balise groups.
 - 4.2.11.1.1 Note: Braking curves may differ between ERTMS/ETCS and the national Class B.
- 4.2.11.2 A temporary speed restriction in advance of the ETCS border, i.e. within the level STM area, and sent to the train, allows this speed reduction to be taken into consideration by the train before entering the level STM area. Even if the national system is installed in rear of the ETCS border, TSRs located in advance of the ETCS border (in the level STM area) may only be read by the STM in state Hot Standby and supervised when in state Data Available. This must be taken into account for the level transition announcement so that STM is in Hot Standby in rear of the location where the national infrastructure is installed.
- 4.2.11.3 This has no further impact on the transition procedure and is not considered in chapter 5.

4.2.12 Management of speed restrictions beginning in rear of the ETCS border

- 4.2.12.1 In a ETCS level 1 FS area the driver observes only cab signalling and must not observe most line side signals. Due to lack of harmonized rule in the OPE TSI [1], the driver must observe line side signals according to national operational rules for instance, if the level transition to level STM is announced or if the driver has acknowledged the level transition.
- 4.2.12.2 If a speed restriction is beginning in rear of the ETCS border in level 1 and ending in advance of the ETCS border in the level STM for the minimum safe front end, the driver might have not observed the line side signal for the speed restriction in level 1 (see 4.2.12.1 or 4.2.12.6) and is therefore not aware of the still relevant speed restriction in the level STM area. Even if the train exits level 1 with the correct speed restriction, the driver might accelerate the train before the safe train

end has passed the end of the speed restriction. The following possible solutions could solve this issue.

- 4.2.12.3 The STM should supervise speed restrictions in level STM until the minimum safe front end has passed the end of the speed restriction. National trackside STM infrastructure for the relevant speed restrictions should be placed in rear of the ETCS border in the level 1 area or at the ETCS border. This is valid if the STM train device fulfil the STM state HS requirements in SUBSET-035 [3].
- 4.2.12.4 Additional line side signals for the speed restriction may be repeated at the ETCS border, so that the driver can observe the speed restriction in level STM area. This is only an operational solution and might not be sufficient for national safety requirements.
- 4.2.12.5 These solutions might not be possible for route depending speed restrictions in rear of the ETCS border and diverging routes to level STM because of points. In addition, in this situation the level announcement might be sent quite late if the route is set to level STM area and the train has already passed the relevant speed restriction line side signal.
- 4.2.12.6 To avoid this situation a possible solution is to plan a distance of at least the maximum train length between the location where a speed limit (e.g. speed at point or TSR) changes and the level transition to level STM as depicted in the Figure 3.

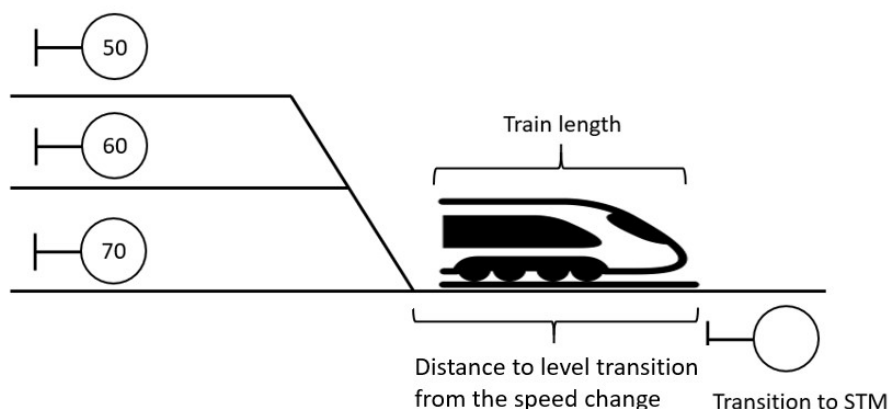

Figure 3: Train length shall be smaller than the distance to the level transition point

- 4.2.12.7 As possible alternative solution a balise group could send a text message with the still relevant speed restriction (either relevant for train front end or for train rear end, depending on the end of the speed restriction), if the level transition to level STM is announced.
- 4.2.12.8 This issue is project specific and is not considered in chapter 4.2.17.

4.2.13 Management of National Values

- 4.2.13.1 The ERTMS/ETCS train that exits the ETCS area should have the correct National Values stored on-board for the level STM area. This can be achieved by transmitting them from a balise group at the ETCS border (see section 5.3.3).

4.2.14 Manual level selection in rear of the ETCS border

- 4.2.14.1 The train driver may manually select level when the train is at standstill. In case level STM is available for manual selection (in the table of trackside supported levels or with no table on-board), the driver could change to level STM already in rear of the border and (depending on the national system) move in the level 1 area.
- 4.2.14.2 This is potentially unsafe and can be avoided by using a packet 46, Conditional Level Transition Order, not including level STM in a balise group in rear of the location where the level transition is announced to avoid possible conflicts between packets 41 and 46, because the on-board behaviour is unclear in ERTMS/ETCS Baseline 2.
- 4.2.14.3 As the train is expected to be operated in the level applicable for the area where it is located, this issue is not further considered in chapter 5.

4.2.15 Protect EOA in rear of the ETCS border

- 4.2.15.1 When the EOA is close to the ETCS border there is a risk that the level transition to level STM is performed before the min safe front end of the train reaches the EOA due to odometer inaccuracies and after switching to level STM the train may no longer obey its previous EOA.
- 4.2.15.2 This is solved by proper engineering of the ETCS border in relation to the last EOA in rear of the border and this issue is considered in section 5.2.

4.2.16 Approaching the border in SR mode

- 4.2.16.1 Trains may be moving in SR mode in rear of the ETCS border for various reasons, e.g. after start-of-mission or after selecting Override EOA.
- 4.2.16.2 Preventing trains to pass the ETCS border in SR mode is out-of-scope of this guideline as this is considered normal procedure for protecting a specific location, e.g. by using a balise group with ETCS packet 137: Stop if in SR. Thus, preventing trains to pass the border in SR is not considered in chapter 5.
- 4.2.16.3 Trains that are supposed to approach the ETCS border in SR mode should preferably receive a level transition announcement in rear of the border to prepare both the driver and the STM for the transition to the national system, as for normal train movements. This is considered in section 5.1.

4.2.17 Restrictive mission at the level transition

- 4.2.17.1 A driver must never face a restrictive mission (stop or speed decrease) located just after the level transition to level STM without being warned at the appropriate distance ahead of the beginning of this restriction.
- 4.2.17.2 In particular, train with good braking performance (dotted in Figure 4) may not display the braking indication to the driver before the transition point. As an example, when the speed drops right after the border transition because there is a closed signal near the border transition. Due to very short braking distances, the train could approach the closed signal in overspeed.

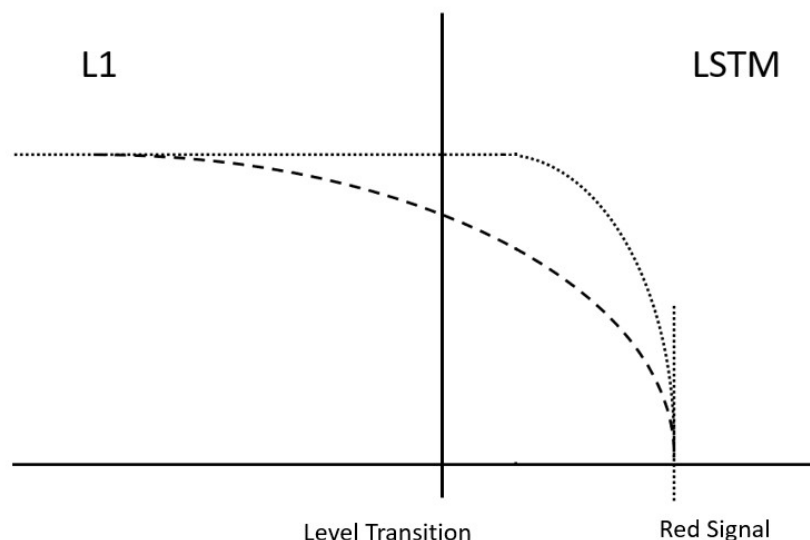

Figure 4: Train with good braking performance (dotted) and poorer braking performance (dashed)

- 4.2.17.3 If the DMI displays warning information received from the STM in HS state (see 10.5.2.6, 10.5.2.6.1 and 10.5.2.6.2 of SUBSET-035 [3]), when it switches to DA state, LTA and LTO BG could be located so that there is a STM wayside device in between them to warn for the restrictive mission after the LTO BG.
- 4.2.17.4 If the LTA BG is located ahead of the STM wayside device, a specific operational rule can be necessary to ask the driver to take into consideration the most restrictive mission among the one displayed on the DMI and the one displayed by the lateral signalling (if any) when a level transition is announced to the driver.
- 4.2.17.5 If the STM warning information is not displayed to the driver when the STM device switches to DA state, the protection of the speed reduction or the stop must be ensured by an ETCS speed reduction at the level transition border.
- 4.2.17.6 This topic is project specific and is not considered in chapter 5.
- 4.2.18 Level transition with STM not present and no other levels are admitted**
- 4.2.18.1 According to SUBSET-026 [2] chapter 5, when trackside orders a transition to a STM Level (packet 41) which is not available on-board, the OBU shall nevertheless make the transition.
- 4.2.18.2 The issue is the following: if there are no other levels in the list of the ordered level(s) in packet 41 (e.g. L0 is not allowed), the transition takes place, but train protection is not more provided unless national system is present and active (but unknown to EVC).
- 4.2.18.3 The STM not being present, no STM control function is active (i.e. no STM Max Speed).
- 4.2.18.4 In this case, the OPE TSI [1] refers to non-harmonised rules.

- 4.2.18.5 According to SUBSET-026 [2] 5.10.2.6 and 5.10.2.7.1, the OBU has to indicate to the driver the new STM level showing the name of the STM which shall be stored OBU according to SUBSET-035 [3] 7.4.1.1.7.
- 4.2.18.5.1 Note: Storing STM names is not more foreseen in B3 specification, see SUBSET-035 v3.1.0 and v3.2.0 [8], which is valid for B3MR1 and B3R2 (SUBSET-026 v3.4.0 and v3.6.0 [9]).
- 4.2.18.6 The trackside engineering (or route compatibility rules) should consider this issue to prevent trains from running unprotected within STM area unless national operational rules allow it.
- 4.2.18.7 This topic is project specific and is not considered in chapter 5.

5. Recommended solutions

5.1 Level transition announcement and level 1 MA

5.1.1 Basic considerations

5.1.1.1 Functional step 1 is about the process to announce the transition to level STM and authorise the ERTMS/ETCS on-board to pass the ETCS border.

5.1.1.2 The following issues from section 4.2 must be considered in this functional step:

- Loss of route protection in the route from the ETCS border (see 4.2.1)
- Authorisation across the ETCS border (see 4.2.2)
- Allow level transition at line speed (see 4.2.3)
- Announcement of level transition (see 4.2.5)
- Driver acknowledgement of level transition (see 4.2.6)
- Avoid level transition announcement for diverging trains (see 4.2.7)
- Manual cancellation of the route from the ETCS border (see 4.2.8)
- Start of mission in rear of the ETCS border (see 4.2.9)
- Approaching the border in SR mode (see 4.2.16)

5.1.1.3 It is recommended to announce the transition to level STM with the Movement Authority across the ETCS border into the level STM area.

5.1.1.4 It is also recommended to engineer a request for driver acknowledgement of the level transition in rear of the ETCS border.

5.1.2 Track layout

TRACK LAYOUT	BG	DESCRIPTION	BG INFORMATION
<p>Switchable balise group Fixed balise group</p>	LTA	Level Transition Announcement	Packet 41: Level Transition Order announcing the transition to level STM at the ETCS border Packet 12: Level 1 Movement Authority (together with applicable packets)
	LTC	Level Transition Cancellation (optional)	Packet 41: Level transition order with immediate transition to level 1 ; this cancels the announced transition to level STM
	LTA 2	Level Transition Announcement (optional)	Packet 41: Level Transition Order announcing the transition to level STM at the ETCS border Packet 12: Level 1 Movement Authority (together with applicable packets)
	LTO	Level Transition Order	Packet 41: Level transition Order with immediate transition to level STM Optional Packet 137: Stop if in SR

Table 2: Balise groups used for functional step 1

- 5.1.2.1 The LTA balise group provides level transition announcement to level STM (and the applicable STM) together with the Movement Authority to cross the ETCS border. This could be a particular balise group in the track or any balise group that can authorise the train to cross the border, as long as it fulfils the requirement for distance D1, as described further below.
- 5.1.2.2 The distance D1 has to consider the applicable line speed with the times shown in section 5.1.3 for evaluating the LTA, for the STM to report state Hot Standby in rear of the national infrastructure and the request for driver acknowledgement of the level transition. In case there are multiple tracks leading to the border, the distance should be calculated for each track based on this specific speed profile; in addition, see 5.3.2.2.
- 5.1.2.3 The LTC balise group sends an immediate level transition order to level 1 to cancel a previously received announcement to level STM. The LTC balise group is only needed if the train can be routed away from the border after receiving the transition announcement.
- 5.1.2.4 If used the LTA2 balise group allows the STM to perform the transition to Hot Standby state if no level transition announcement has been received yet, e.g. after start-of-mission near the ETCS border.
- 5.1.2.5 The LTA2 balise group can also be used to update the Movement Authority in case of manual route cancellation or loss of route protection.

- 5.1.2.6 At all locations in advance of the LTA balise group where a start-of-mission can be foreseen, it should be considered to add additional LTA2 balise groups.
- 5.1.2.7 When the EOA is closely in rear of the ETCS border, the LTA2 balise group can be used to update the odometry to avoid that a train makes the transition to level STM before the EOA is passed with the min safe front end. For this the LTA2 balise group must be part of the linking data of the level 1 MA.
- 5.1.2.8 The distance D2 between the LTA2 balise group and the LTO balise group depends on the time required for the STM to reach the state HS, the SR speed, the requirement to read national system trackside equipment when the STM is in state HS and if this situation is regarded as a normal or degraded situation; in addition see 5.3.2.2.
- 5.1.2.9 If the level transition announcement, i.e. LTA balise group or LTA2 balise group, is placed in an infill balise group, the transition order should be within the non-infill part of the balise telegram (i.e. above packet 136) to avoid misinterpretation of the transition order announcement.

5.1.3 Sequence diagram

5.1.3.1 Figure 5 below provides a visual representation of the sequence diagram for step 1.

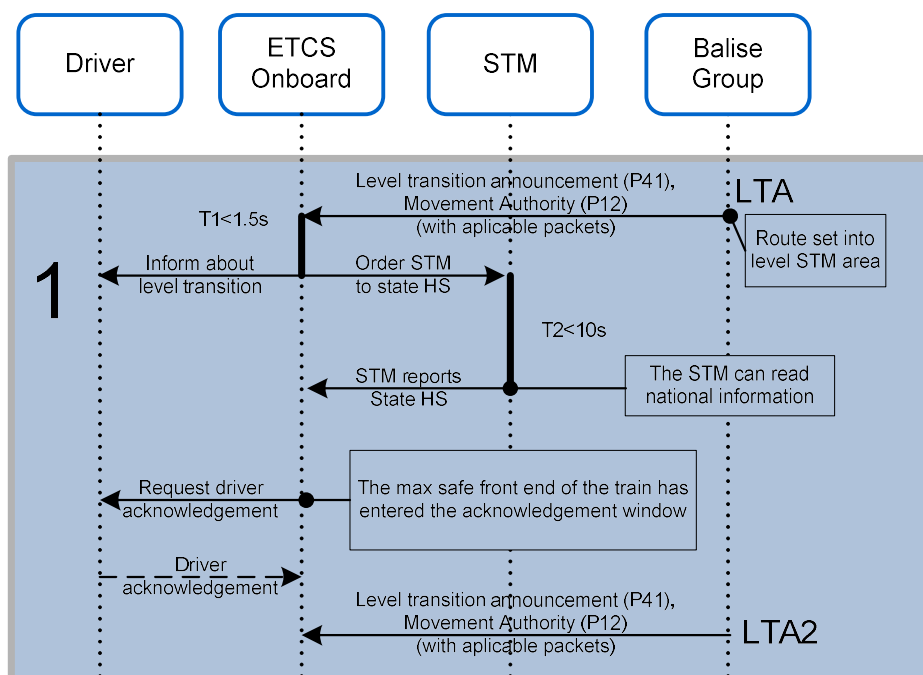

Figure 5: General sequence diagram for step 1

5.1.3.2 The LTA balise group sends the MA and the level transition announcement to level STM for the location of the ETCS border when a route is set into the level STM area.

- 5.1.3.3 T1 is the maximum time for the ERTMS/ETCS on-board to indicate a status change to the driver after receiving information from a balise group (see SUBSET-041 [4] 5.2.1.3).
- 5.1.3.4 When receiving the announcement for transition to level STM, the ERTMS/ETCS on-board orders the STM to state Hot Standby This must be done sufficiently in rear of the national system's infrastructure for the STM to be in state Hot Standby before it needs to read relevant national information.
 - 5.1.3.4.1 Note: According to the ERTMS rules in the OPE TSI [1], the driver shall prepare for national rules at the transition location when the announcement to level STM is shown.
- 5.1.3.5 T2 is the maximum time allowed for the STM to report being in state Hot Standby (HS) according to SUBSET-035 [3], otherwise the ERTMS/ETCS on-board will consider the STM as failed or not connected; for the consequences see 5.1.5.
- 5.1.3.6 The LTA balise group sends a MA into the level STM area (see 5.3.1).
 - 5.1.3.6.1 Note sending the transition announcement with the MA into the level STM area avoids the risk that a transition to level STM can be made, due to odometer inaccuracy, in rear of the ETCS border, which could result in an EOA not protected by ERTMS. This also prevents that a fixed announced transition to level STM has to be cancelled for a diverting route from the level STM area.
 - 5.1.3.6.2 Note: It may not always be possible to give a MA to pass the ETCS border already when it is necessary to give the announcement, e.g. if the STM needs to be in Hot Standby far in rear of the border. This is handled by the alternative solution described in section 5.1.4.
 - 5.1.3.7 To allow the train with a failed STM being stopped in rear of the level STM area the announcement to level STM should be issued on braking distance from the level STM area. The calculation of this distance D1 can be found in section 5.1.2.2 and includes the time T2 required for the STM to perform the transition to Hot Standby state and time T1.
 - 5.1.3.7.1 Note: When the STM has not reported the Hot Standby state within T2 the ERTMS/ETCS on-board considers the STM as failed and is assumed to set the maximum STM speed at the transition to zero and the train is braked to standstill (see SUBSET-035 [3] 7.4.2.2.2).
 - 5.1.3.7.2 Note: It may be a national requirement for the train to be equipped with the necessary national STM and if the train should be stopped when the STM is detected as failed or not connected.
- 5.1.3.8 The request for acknowledgement of the transition to level STM is shown when the max safe front end enters the acknowledgement area defined by L_ACKLEVELTR in the transition announcement.

- 5.1.3.8.1 Note: When the transition is not acknowledged before making the transition a post-acknowledgement is required within 5 seconds after the transition occurs as otherwise the train will be braked to standstill until the transition is acknowledged.
- 5.1.3.8.2 Note: According to the ERTMS rules in the OPE TSI [1], the driver shall apply national rules when the acknowledgement to level STM is shown.
- 5.1.3.9 If the authorisation to pass the ETCS border into the level STM area is revoked the transition order to level STM shall be revoked to indicate to the driver that the transition is cancelled. This can be done by an immediate transition to level 1 in the LTC balise group. In principle, any balise group that authorises the train to deviate from the border can act as a LTC by additionally giving a transition order to level 1.

5.1.4 Alternative solutions

- 5.1.4.1 The alternative solution implies that the rules for sending the level transition announcement and the Movement Authority are independent from each other.
- 5.1.4.2 In the alternative solution the Movement Authority into the level STM area is provided by a balise group without the level transition announcement. The level transition announcement to level STM shall be sent by the LTA balise group without providing the Movement Authority.
- 5.1.4.3 The distance for placing the LTA balise group announcing the level transition is the same as described in section 5.1.2.2.
- 5.1.4.4 After the level transition announcement, the ERTMS/ETCS on-board equipment will make the transition according to the travelled distance of the estimated front end of the train and this depends on the actual accumulated odometer inaccuracy. In case the transition should be performed at the ETCS border, the level transition order should announce the transition for a location in advance of the border. Then the transition is executed when reading the LTO balise group. In that case the announced location must consider the possible inaccuracy when making the transition based on the estimated train front end somewhere near the border.
 - 5.1.4.4.1 Note: This can result in a delayed transition when the LTO balise group is not read.
 - 5.1.4.4.2 Note: Any balise group in rear of the ETCS border could provide the Movement Authority into the level STM area.
 - 5.1.4.4.3 Note: The LTA balise group could be a fixed balise group when no diverging tracks are in advance of the LTA balise group.

5.1.5 Degraded situations

- 5.1.5.1 The following degraded situations are related to this solution:
 - 1) Failure to read the LTA balise group
 - 2) Failure to read the LTC balise group
 - 3) Failure to read the LTA2 balise group
 - 4) Failure of the STM to report state HS

- 5.1.5.2 The consequence of the degraded situation 1) can result in a situation that the level 1 MA to pass the ETCS border cannot be sent. The redundancy of balise for MA assignment in a level 1 area is outside the scope of this guideline.
- 5.1.5.3 The consequence of the degraded situation 1) is that the train will not be informed about the upcoming level transition and unable to read information from the national system in time. This risk can be mitigated by repeating the information in other balises. For the recommended solution this should not be a problem as the announcement is given with the Movement Authority to pass the ETCS border and therefore any balise group can act as LTA. For the alternative solution with the announcement in a specific balise group, this can be mitigated by repeating it in another balise group. Depending on the actual project, the location of the redundant LTA balise group (e.g. a LTA2) may also need to full fill the requirement for the STM to reach Hot Standby state.
- 5.1.5.4 The consequence of the degraded situation 2) is that the announcement may not be cancelled for diverting routes. As a result, the train will make the level transition to level STM after travelling the announced distance and possible being braked by lack of information from the national system. This risk can be mitigated by a redundant LTC balise group or by using an LTA balise LTA giving the transition order depending on route locking towards the ETCS border.
- 5.1.5.4.1 Note: For the recommended solution, this is mitigated by having any MA for a diverging route include a level transition order for level 1 to cancel any previous announcements for level STM.
- 5.1.5.5 The consequence of the degraded situation 3) is that the ERTMS/ETCS on-board equipment does not relocate. As a result, the train may make the transition to level STM instead of being tripped by ETCS on overpassing the EOA. This risk can be mitigated by a redundant LTA2 balise group or linking reaction service brake or trip.
- 5.1.5.6 Another consequence of the degraded situation 3) can be that if the LTA2 balise group is not read by a train without level 1 MA, e.g. train started in advance of the LTA balise group, the transition announcement to level STM is not given. Resulting that the STM is not ordered to Hot Standby state. The transition to level STM and the Data Available state will be ordered immediately by the LTO balise group (see functional step 2). If a direct transition from Cold Standby state to Data Available state is an issue depends on the behaviour of the STM.
- 5.1.5.7 Another consequence of the degraded situation 3) is that if the LTA2 balise group includes a MA with trip order to prevent unauthorised entry into the level STM area, and the LTA2 balise group is not read by a train in SR mode (without level 1 MA and linking information) the MA with trip order is not given, and the train may not be stopped.
- 5.1.5.8 The consequence of degraded situation 4) is that the ERTMS/ETCS on-board orders the STM to Failure state and sets the STM max speed to zero; see SUBSET-035 [3] 7.4.1.2.2, 7.4.1.2.3 and 7.4.2.2.2.

5.2 Level STM Transition

5.2.1 Basic considerations

5.2.1.1 Functional step 2 is about the transition to level STM. The following issues from section 4.2 must be considered in this functional step:

- Approaching the border in SR mode (see 4.2.16)
- Protect EOA in rear of the ETCS border (see 4.2.15)

5.2.2 Track layout

TRACK LAYOUT	BG	DESCRIPTION	BG INFORMATION
	LTO	Level Transition Order	Packet 41: Level Transition Order (immediate transition to level STM) Optional Packet 137: Stop if in SR

Table 3: Balise groups used for functional step 2

5.2.2.1 The LTO balise group is located at the ETCS border and orders immediate transition to level STM. This provides redundancy for the level transition announcement sent by the LTA balise group (see also SUBSET-026 [2] 5.10.1.4).

5.2.2.2 To ensure that a train will be tripped if passing the last EOA in rear of the transition location, the ETCS border and the LTO balise group shall be located at least at the maximum odometer confidence interval in advance of the last EOA in the level 1 area.

5.2.2.2.1 Note: If there is no LTA2 balise group with trip order or if a train can perform start-of-mission between LTA2 balise group and LTO balise group, a “stop if in SR” packet can be sent by LTO balise group to prevent a train without authorisation to enter the level STM area. To avoid that this packet provokes an undesired brake intervention in SR operational procedures shall either prohibit passing the transition location in SR or require “override EOA” to be used for the transition location.

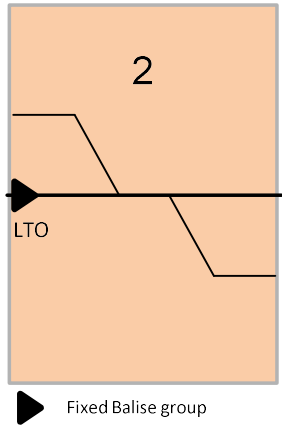
5.2.3 Sequence diagram

5.2.3.1 Figure 6 below provides a visual representation of the sequence diagram for step 2.

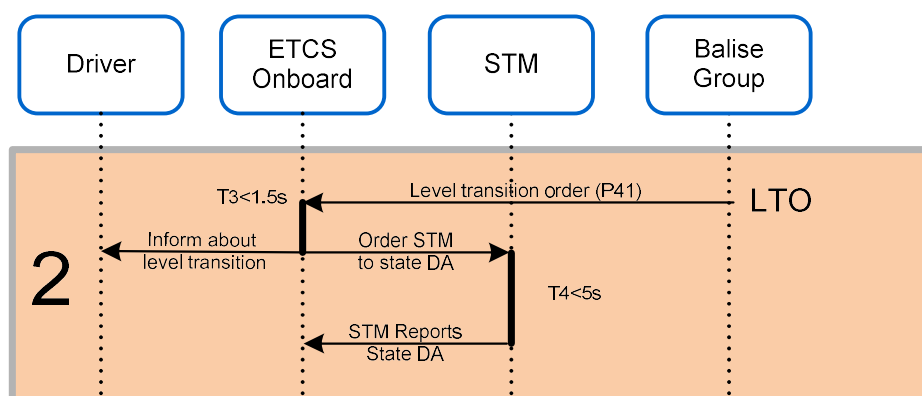

Figure 6: General sequence diagram for step 2

5.2.3.2 T3 is the maximum time for the ERTMS/ETCS on-board to process the information received from the LTO balise group before presenting it on the driver DMI according to SUBSET-041 [4] 5.2.1.3. The ERTMS/ETCS on-board also orders the STM to state Data Available (DA).

5.2.3.3 T4 is the time within which the STM is expected to report state Data Available (see SUBSET-035 [3]), otherwise the ERTMS/ETCS on-board considers the STM as failed; for the consequences see 5.2.5.

5.2.3.4 The trackside engineering must consider the time of T3 + T4 (6,5 seconds) before ETCS takes a safe reaction (e.g. applying the brakes) after the transition location, either because the STM did not report DA state in due time or because of a command from the STM.

5.2.4 Alternative solutions

5.2.4.1 For this functional step no alternative solution is applicable.

5.2.5 Degraded situations

5.2.5.1 The following degraded situations are related to this solution:

- 1) Failure to read the LTO balise group
- 2) Failure of the STM to report state DA

5.2.5.2 The consequence of the degraded situation 1) is that the transition to level STM is not made for ETCS on-boards (including ETCS on-boards in SL, NL mode) without an announcement. This can be mitigated by balise groups LTA and LTA2 giving the level transition announcement.

5.2.5.3 The consequence of the degraded situation 2) is that when the STM is detected as failed, the on-board will order to Failure state and set the maximum STM speed to zero, resulting in the train being braked (see also SUBSET-035 [3] 7.4.1.4).

5.3 General Recommendations for Transition to level STM

5.3.1 Authorisation across the ETCS border

- 5.3.1.1 The authorisation to pass the ETCS border can be implemented with either as a MA including track description information and EOA inside the level STM area, or as (STM) target speed at the ETCS border i.e. as a LOA including speed restrictions at and in advance of the ETCS border as supervised by the STM.
- 5.3.1.2 Both EOA and LOA require that the SSP at the ETCS border does not exceed the maximum allowed speed for the national system.
- 5.3.1.3 The EOA has the advantage that it provides the target distance and speed in the level STM area to the driver in the DMI planning area, but it requires information (routes set, SSP, danger points, etc.) from the level STM area.
- 5.3.1.4 Using EOA means that the train calculates the ETCS supervision limits according to the train's specific braking performance and possibly with a proprietary braking model thus, the speed at the border supervised by ETCS can be lower than the allowed speed for the national system.
- 5.3.1.5 Using LOA has the advantage that for most situations it is sufficient to read the aspect of the signal for entering the level STM area. However, it may be needed to provide some track description beyond the border also for the LOA and due to variations in braking performance, the speed provided by the signal aspect may be too restrictive for good braking trains.
- 5.3.1.6 For the LOA the processing time to switch to level STM, 1,5 seconds after reading the LTO balise group, must be taken into account to prevent passing the location of the LOA before the level transition is performed as otherwise the train will be tripped.
- 5.3.1.7 Depending on the STM in use a specific speed can be required to be able to read national system information in rear of the ETCS border. If required, this STM system speed and location must be provided by the trackside system and/or STM if supported; see SUBSET-035 [3]. If handled by the trackside system the SSP in the level 1 MA shall limit the speed from the location where the national trackside equipment is installed up to the ETCS border to respect the maximum system speed of the STM.
- 5.3.1.8 If national train categories are used the STM can limit the maximum speed depending on the train category. The supervised speed shall not be above the allowed speed for the national system.
- 5.3.1.9 To mitigate the potential risk of entering an unlocked route after manual release of the route from the ETCS border, depending on the rules and procedures in use on both sides of the border, when using LOA the MA should consider a timeout for the speed to pass the border and when using EOA the MA should have a section timer for which the stop location is in advance of the border.

5.3.2 Balises

5.3.2.1 The balise groups in the level STM approach area must consist of at least two balises for the information in them to be valid in a defined direction if no linking is available.

5.3.2.2 The trackside engineering may need to consider the possible location of the balise antenna (see SUBSET-040 [6] 4.1.2.2) when reading a balise group and possibly some additional delay depending on the number of balises in the group being read (see SUBSET-036 [7] 4.2.9).

5.3.3 National Values

5.3.3.1 The ERTMS/ETCS train entering the level STM area should have the correct National Values stored on-board, possible for a list of different NID_C. The National Values for the level STM area must be given at latest at the ETCS border and this can be achieved by having them in the LTO balise group. It may also be necessary to provide another set of National Values in rear of the border, e.g. the time and distance for the validity of using Override EOA to pass the ETCS border.

5.3.3.1.1 Note: If giving National Values for the ETCS area in a balise group in rear of the ETCS border, then the National Values may need to be changed if the train is routed away from the level STM area.